

The logo for Zutronic, featuring a stylized 'Z' with a red and white diagonal split, followed by the word 'utronic' in a white, italicized sans-serif font with a registered trademark symbol.

Zutronic®

NEVER WITHOUT POWER

GENERAL CATALOGUE

INDEX

Industrial DC UPS battery chargers

DC-UPS Z-DXCB, DC power supply for DIN rail	4
TITANIUM ECO 1R-CH - Rectifier Battery Charger, single branch IGBT based	6
TITANIUM PLUS 1R-CH - Rectifier Battery Charger, single branch IGBT based	8
TITANIUM PLUS 1R-SCR - Rectifier Battery Charger, single branch SCR-based	10
TITANIUM PLUS 2RP-CH - Rectifier Battery Charger, double branch parallel IGBT-based	12
TITANIUM PLUS 2RP-SCR - Rectifier Battery Charger, double branch parallel SCR-based	14
TITANIUM PLUS 2R-CH - Rectifier Battery Charger, double branch IGBT-based	16
TITANIUM PLUS 2R-SCR - Rectifier Battery Charger, double branch SCR-based	20
HMI TITANIUM PLUS	24
HMI TITANIUM PLUS-E	25

Industrial AC UPS and DC/AC inverters

SINE and MICRON - DC/AC Industrial DC/AC inverter 1Ph output	26
IRON - Industrial DC/AC inverter 1Ph or 3Ph output	31
WAVE - Industrial AC UPS	33

ACCESSORIES

Battery Monitoring Unit (BMS)	35
Batteries	36

SERVICES

System start-up, after sale service, battery replacement	37
--	----

zutronic[®]

NEVER WITHOUT POWER
GENERAL CATALOGUE



Zutronic®

Zutronic is a Company specialized in the design and production of customized emergency power systems (AC and DC UPS) for Utilities, Oil & Gas, Energy, Renewables, Transportation, Industrial, Service and IT applications. The Company has an experience of more than 20 years in the energy conversion sector and has been involved in hundreds of supplies of customized solutions to the major EPC Contractors for international projects, acquiring over the years an important know-how which is constantly recognized. Since its founding date, the Company stood out for its technical competence and reliability to support the Clients in all the project phases.

The products are designed and manufactured in the plant located in the city of Mantova, while the headquarter and sales office is located in Brembate di Sopra (BG), in the heart of the Italian industrial and electrical engineering pole, 40 km far from Milan.

APPLICATIONS

- MV ELECTRICAL PANELS AND SUBSTATIONS
- ELECTRIC AND HYDROELECTRIC POWERSTATION
- TECHNOLOGICAL INSTALLATIONS
- FACTORIES & INDUSTRIAL PLANTS
- TRANSPORTATION
- OFFICES AND BUILDINGS
- HOSPITALS
- RENEWABLES

Giovanni Tartaglia

Sole Director



SOME OF OUR CLIENTS:



DC-UPS

INDUSTRIAL DC UPS BATTERY CHARGERS

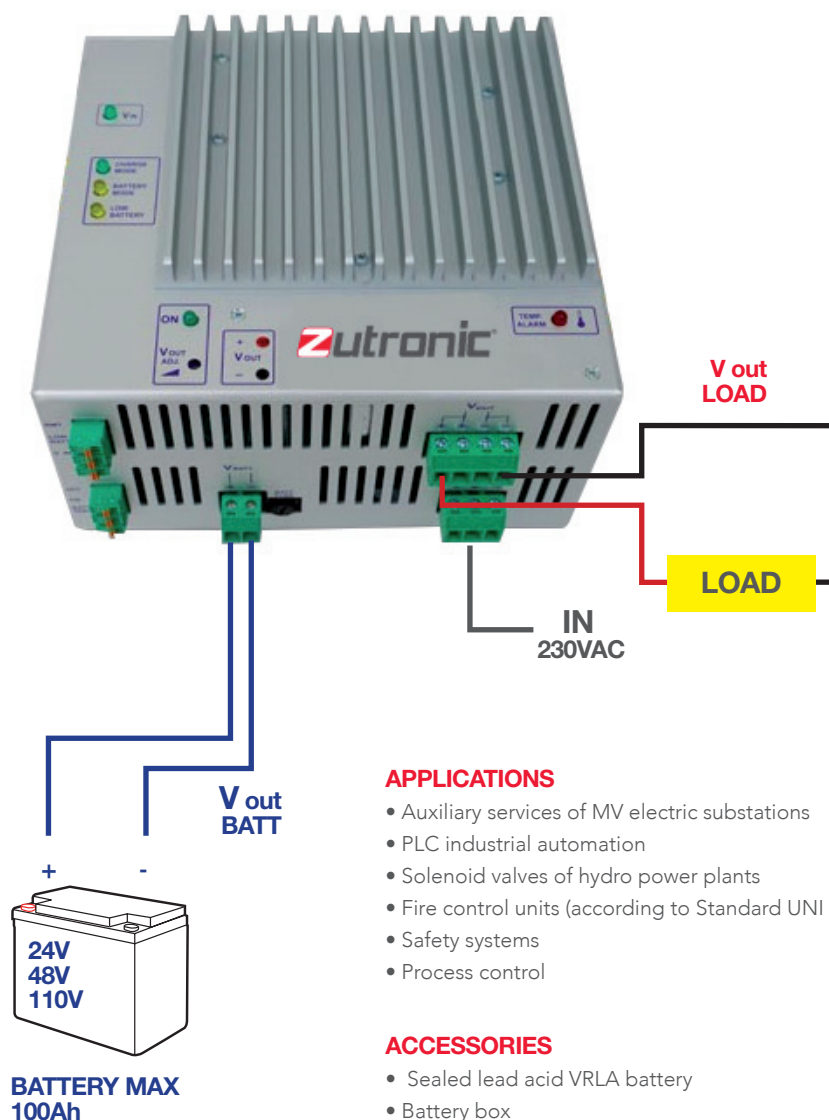

Z-DXCB series for DIN rail installation

The power supply system ZUTRONIC "Z-DXCB" series, combined with batteries, is designed to work as a uninterruptible supply system (DC UPS) for small and medium sized applications.

The battery is connected in parallel to the load to guarantee the continuous power supply without interruptions in case of AC mains failure. The product is designed for installation on the DIN rails inside the switchgear panels.

MAIN FEATURES

- Wide voltage range
- Galvanic insulation IN/OUT
- Integrated protection battery fuse (types <500W)
- Internal device for battery disconnection (types<500W)
- Battery efficiency test
- Internal decoupling diode (for parallel with other power supply)
- Reverse polarity Vdc output
- Compliance for the UNI EN54.4 Standard (types <500W)

MODEL	POWER	INPUT VOLTAGE VAC	OUTPUT VOLTAGES
Z151DXCB	150W	88 ÷ 264 VAC wide range PFC (Power Factor Correction)	12 (13,8) VDC 24 (27,6) VDC 48 (55) VDC 110 (125) VDC
Z201DXCB	200W		
Z251DXCB	250W		
Z301DXCB	300W		
Z351DXCB	350W		
Z501DXCB	500W	115 VAC ±20% range 230 VAC ±20% range (Power Factor Correction)	24 (27,6) VDC 48 (55) VDC 110 (125) VDC
Z601DXCB	600W		
Z751DXCB	750W		
Z1001DXCB	1000W		
MODEL	POWER	DIMENSIONS Width x Height x Lenght (mm)	WEIGHT (g)
Z151DXCB	150W	180 x 155 x 105	1900
Z201DXCB	200W		
Z251DXCB	250W		
Z301DXCB	300W	180 x 155 x 120	2200
Z351DXCB	350W		
Z501DXCB	500W	200 x 185x 120	2600
Z601DXCB	600W		
Z751DXCB	750W		
Z1001DXCB	1000W	200 x 200 x 120	2900

D: Output diode for parallel/redundancycoupling.

CEI 0-16: Battery START FUNCTION.

L: SPDT contact for FAULT allarm (replaces the "low battery" alarm on the < 500W types).

T: Tropicalized versions for marine/hars ambient.

	DESCRIPTION	
GENERAL	BATTERY	Suited for sealed lead acid (VRLA) AGM or Gel type
	CHARGING CHARACTERISTICS	IU (in accordo with DIN 41773) – single voltage level
	EFFICIENCY AT 100% LOAD	>80%
	HOLD TIME WITH NO MAINS AND 100% LOAD	80ms
	VOLTAGE DI INSULATION (INPUT/OUTPUT/EARTH/ALARMS)	2kVac - 50Hz 60s
	INSULATION RESISTANCE	>100 Mohm
	MTBF	>1.000.000 hours (T amb +25°C) >500.000 hours (T amb +40°C)
	LIFE TIME	> 7 years (T amb. +25°C)
	COOLING SYSTEM	Natural convection (models from 150W to 600W) Natural convection with forced ventilation with FCD fan control device (models 750W and 1000W)
	MECHANICS	Strong anodized aluminium cases with ventilation grids or fans
	PROTECTION DEGREE	IP20
MOUNTING	DIN 35x15/7,5 mm EN60715	
OUTPUT	NOMINAL VOLTAGE (V)	12-24-48-110 Vdc (from 150W a 350W) 24-48-110 Vdc (from 500W a 1000W)
	RANGE POWER	150 ÷ 1000W
	RANGE OF SETTING	±10% with trimmer
	VOLTAGE STABILITY	0,4% for load variation 10÷90%
	VOLTAGE RIPPLE	≤ 50 mVpp
INPUT	VOLTAGE RANGE	88 ÷ 264 Vac single-phase, 48 ÷ 62 Hz (from 150W to 350W) 115 Vac ±20% or 230 Vac ±20% single-phase, 48 ÷ 62 Hz (500W to 1000W)
	POWER FACTOR	0,99
PROTECTIONS	INPUT	Fuse protection
	OUTPUT	Reverse polarity VDC protection Short circuit Overload Overvoltage OVT overtemperature protection T with automatic restart
	BATTERY	Automatic battery release if voltage exceeds the range ± 20% of the nominal Overcurrent (replaceable fuse)
AMBIENT	OPERATING TEMPERATURE	-10 ÷ +60°C without derating +60 ÷ +70°C with derating <2,5% /°C
	RELATIVE HUMIDITY	95% Max
REMOTE ON-OFF	Contacts for power on and off	
ALARMS	SPDT contacts for "No Mains", "Low battery", "General fault"	
LED SIGNALS	LED SIGNALS "Vin", "Charge mode", "Battery mode", "Low battery", "Power ON", "Temperature alarm", "Fan control" (from 750W and 1000W models)	

TITANIUM ECO 1R-CH

DC POWER SUPPLY SYSTEMS



APPLICATIONS

- Oil & Gas
- Energy production and distribution
- Process controls
- Transportation
- Safety
- Telecommunications
- Tertiary

Single branch IGBT-based

TITANIUM ECO 1R-CH is a Single Branch rectifier, provided with a single IGBT-based AC/DC conversion unit which supplies the loads and simultaneously charges the battery. The rectifier is assembled in an industrial cabinet 1600mm height and can be supplied with sealed Lead Acid and NiCd batteries.

Further, the rectifier is provided with an input insulation transformer and the AC/DC converter is based on a removable rack 19" unit, in order to improve the efficiency, contain the output voltage ripple, and obtain a high MTBF with an extremely low MTTR.

MAIN FEATURES

- Input insulation transformer at power frequency, complete of electrostatic shield
- Rectifier bridge chopper IGBT-based on REMOVABLE UNITS RACK 19" with polarized connector
- Control type: high frequency PWM
- Digital control with microprocessor
- Extended frequency range accepted as input
- Charge curve for every type of sealed lead acid and NiCd battery
- Provided with digital control panel with backlit alphanumeric display
- High efficiency and reliability
- Easy maintenance thanks to the access from the front and the removable power units
- Low residual voltage ripple on output and on batteries
- Automatic and manual battery test to perform a true discharge battery test (Optional)
- Earth fault sensor with POLE+ and POLE-

REMOVABLE AC/DC CONVERTERS

AC/DC converter based on removable rack 19" unit, provided with polarized connectors in order to simplify the replacement in case of failure (very short MTTR).



LED SIGNALS

- SYSTEM OK ●
- SYSTEM FAILURE ●

MULTIPURPOSE BUTTON

- Buzzer OFF

ELECTRICAL MEASURES ON LCD

- Output voltage
- Output current

DISPLAY MESSAGES

- Rectifiers ON
- Overload
- V OUT Rectifiers MAX
- Battery discharging
- Low battery voltage
- End of battery autonomy
- Grounding pole
- Ongoing/failed battery test

SINGLE-LINE DIAGRAM

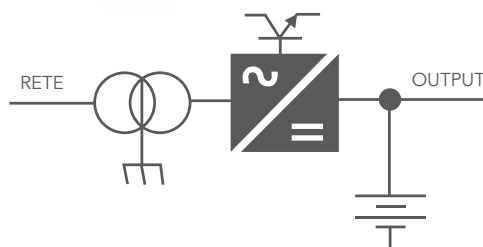

TITANIUM ECO 1R-CH

GENERAL	BATTERY	Suited for sealed (VRLA) Lead Acid or NiCd battery		
	CHARGING CHARACTERISTICS	IU (according to DIN 41773)		
OUTPUT	NOMINAL VOLTAGE (V)	24	48	110
	CURRENT RANGE	10 ÷ 60 A		
	MAXIMUM POWER (W)	1440	2880	6600
	RIPPLE NOISE (RMS)	≤ 0.5% Vn		
	Vout SETTING RANGE	+/- 5%		
	STABILITY	+/- 1%		
	Vin VARIATION SETTING	+/- 1%		
	LOAD VARIATION SETTING	+/- 1%		
	START-UP TIME	2 sec.		
	INPUT	VOLTAGE RANGE	230 Vac ±10% or 400 Vac ±10% (1F or 3F)	
INPUT FREQUENCY		50 ÷ 60 +/-7%		
EFFICIENCY (Typ.)		≥ 90 %		
I/O INSULATION		4kV		
PROTECTIONS	INPUT	Automatic circuit breaker		
	BATTERY	Fuses		
	OVERLOAD	2In x 5mS without battery 3In x 30S with battery		
	CURRENT CURVE	Constant		
	OVERVOLTAGE	+ 10% Vn		
	UNDERVOLTAGE	- 50% Vn		
	OVERTEMPERATURE	Shut down - Restart Automatic restart after temperature reset		
ALARMS SPDT 5Amp/250Vac	BATTERY LOW VOLTAGE			
	GENERAL FAILURE			
	MAINS FAILURE			
AMBIENT	OPERATING TEMPERATURE	-10+40°C		
	OPERATING HUMIDITY	2090% (NO COND.)		
	STORAGE TEMPERATURE	-20+50°C		
STANDARDS	MARKING	CE		
	PROTECTION DEGREE	IEC 60529		
	EMC	EN 61000-6-2 EN 61000-6-4		
	STATIC CONVERTERS	EN 60146-1-2		
EXECUTION	DC-UPS (performance, routine test, requirements)	IEC 62040-5-3		
		Metallic cabinet for floor mounting dimensions WxLxH 600x650x1600		
PROTECTION DEGREE (closed door)		IP30		
COLOR		RAL 7035		

AVAILABLE ACCESSORIES (OPTIONAL)

- uP card for function: AUT/MAN BATTERY TEST
- uP card for function: BOOST & MANUAL CHARGE
- uP card for function: TEMPERATURE COMPENSATION
- External Temp. Probe (3mt. cables max)
- uP card for function: DC EARTHED PROBE (with polarity discrimination +/-)
- END DISCHARGE POWER CONTACTOR

* Relay normally operating in positive safety



TITANIUM PLUS 1R-CH

DC POWER SUPPLY SYSTEMS



APPLICATIONS

- Oil & Gas
- Energy production and distribution
- Process controls
- Transportation
- Safety
- Telecommunications
- Tertiary

STANDARD FUNCTIONS

- AC mcb with cont. aux.
- Floating charge
- Boost charge
- Manual charge
- Temperature compensation
- Test battery function
- **BEA** function (Battery Efficiency Analysis)
- DC earth pole sensor
- Relay alarm card

SINGLE-LINE DIAGRAM

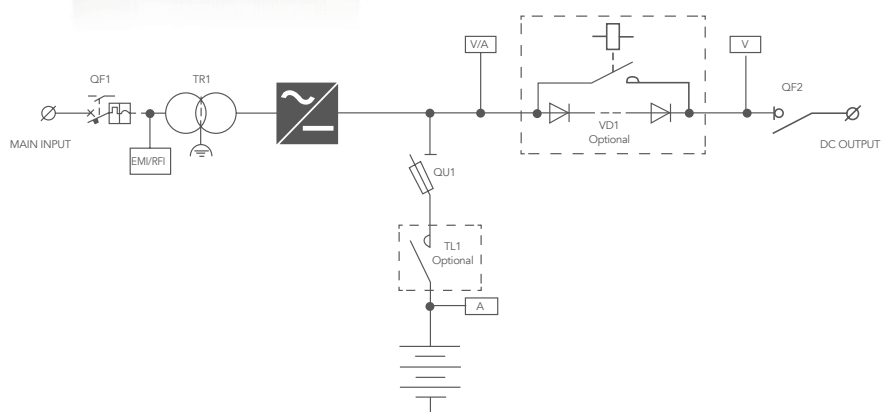

Single branch IGBT-based

TITANIUM PLUS 1R-CH is a Single Branch rectifier, provided with a single IGBT-based AC/DC conversion unit which supplies the loads and simultaneously charges the battery. The rectifier is assembled in an industrial cabinet 2000mm height and can be supplied with sealed or vented Lead Acid and NiCd batteries.

The AC/DC conversion unit is removable, in order to improve the efficiency and obtain an high MTBF with an extremely low MTTR. Further, the rectifier is provided with an input insulation transformer, in order to contain the output voltage ripple, and features our latest HMI, including a touchscreen display 7" with integrated web server and MODBUS TCP/IP communication protocol.

MAIN FEATURES

- Input insulation transformer at mains frequency, with an electrostatic shield
- Bridge rectifier Chopper **IGBT on REMOVABLE UNITS**
- Control type: **High frequency PWM**
- System control with industrial **PLC on REMOVABLE UNITS**
- Charge curve for each type of battery (AGM - GEL - PB - NI-CD) 3 charging levels including manual charging complete with safety timer
- HMI - Digital control panel with touchscreen display 7" with integrated Web server
- High efficiency and reliability
- Easy maintenance with access from the front and removable power units
- Extended frequency range accepted as input
- Low residual ripple as output and on batteries (RIPPLE)
- Automatic and manual battery test (performing a true discharge battery test)
- DC polarity on the ground sensor
- MODBUS TCP/IP communication (slave – server)
- Alarm cards with 3 fixed relays and 4 completely programmable by user
- Temperature compensation with PT100 sensor and correction coefficient (Vel/°C) settable by the user
- **AUTOMATIC SAFE MODE** function to ensure continuity of power supply even in case of control failure

HMI PANEL

- Output voltage
- Output current
- Current battery charge
- Battery temperature



SIGNALS AND MEASURES

- AC Mains ON
- AC/DC ON
- Rectifier High voltage output
- Rectifier Low voltage output
- Floating charge
- Boost charge (x)
- Manual charge (x)
- Active temperature compensation (x)
- Battery charging current limitation ON
- Positive grounded pole
- Negative grounded pole
- Output overload
- Battery test in progress
- Battery test failed
- Operating from batteries
- Low battery voltage
- End of battery drain
- High battery temperature (x)
- AC input MCB OFF AC

COMMUNICATION

(Modbus slave TCP/IP)

Individual word for electrical parameters:

- Output voltage to loads
- Output current to loads
- Current battery charge
- Battery temperature

DoubleWord alarms:

- Showing all the signals present on the HMI

(x) HMI - enable function

TITANIUM PLUS 1R-CH

GENERAL	BATTERY	Suited for sealed (VRLA) or vented Lead Acid or NiCd battery			
	CHARGING CHARACTERISTICS	IU (according to DIN 41773) floating, boost and manual charging			
OUTPUT	NOMINAL VOLTAGE (V)	24	48	110	
	CURRENT RANGE	10 ÷ 100 A			
	MAXIMUM POWER (W)	2400	4800	11000	
	RIPPLE NOISE (RMS)	1%			
	V _{out} SETTING RANGE	+/- 5%			
	VOLTAGE STABILITY	+/- 1%			
	V _{in} VARIATION SETTING	+/- 1%			
	LOAD VARIATION SETTING	+/- 1%			
	START-UP TIME	2 sec.			
	INPUT	VOLTAGE RANGE	single-phase 230 Vac +/- 10% or three-phase 400Vac +/- 10%		
INPUT FREQUENCY		50 ÷ 60 +/-7%			
EFFICIENCY (Typ.)		≥ 90 %			
I70 INSULATION		4kV by transformer			
PROTECTIONS	INPUT	Automatic circuit breaker			
	BATTERY	Fuses			
	OUTPUT	Switch			
	OVERLOAD	2In x 5mS Shut down for 250mS - restart aut.			
	CURRENT CURVE	Constant			
	OVERVOLTAGE	+ 10% Vn			
	UNDERVOLTAGE	- 50% Vn			
	OVERTEMPERATURE	Shut down. Automatic restart after temperature reset			
	ALARMS	ALARM CARD WITH N.3 RELAYS SPDT 5A/250VAC	AC Mains presence, General Failure, Low Battery voltage		
		N. 4 USER PROGRAMMABLE RELAYS VIA HMI PANEL			
AMBIENT	OPERATING TEMPERATURE	-10+40°C			
	OPERATING HUMIDITY	< 95% without condensation			
	STORAGE TEMPERATURE	-20+70°C			
	NOISE LEVEL	according EN50091 < 60 dBA (typical value with forced ventilation in operation)			
STANDARDS	MARKING	CE			
	PROTECTION DEGREE	IEC 60529			
	EMC	EN 61000-6-2 EN 61000-6-4			
	STATIC CONVERTERS	EN 60146			
	DC-UPS (performance, routine test, requirements)	IEC 62040-5-3			
PROTECTION DEGREE (closed door)		IP31 standard, others on demand			
COLOR		RAL 7035 cabinet - RAL7012 roof and base			

* Relay normally operating in positive safety

The **SYSTEM CONTROL** is now based on an expandable Industrial PLC, characterized therefore by a very high reliability as well as by a considerable flexibility, it allows to satisfy a greater number of technical needs and consequent applications. This section, which constitutes the "intelligent" heart of our system, is now made in a special drawer located on the inside of the main door of the cabinet and **FULLY REMOVABLE** thanks to the presence of a polarized connector. This solution introduces a very important advantage, in fact it is possible to replace this assembly while hot, with the machine running, without turning off the system.

This is possible as the AC / DC conversion units recognize the loss of communication with the drawer and set themselves up in **AUTOMATIC SAFE MODE**, actually working independently and guaranteeing continuity of operation.

Once the drawer has been replaced and the connection re-established, the AC/DC units will return to operate under the automatic control of the PLC, resuming normal and complete operation. The HMI (Human Machine Interface) system has also been renewed, which now includes a touch panel, capacitive, 7 "with excellent visibility characteristics, mechanical resistance to wear and connectivity with the outside world. Finally, a great deal of space was reserved for **REMOTE CONNECTION**, in fact now it is possible to control, parameterize and manage these systems in absolute safety through the **INTERNET** network thanks to the standard presence of the **WEB SERVER** function. This has an undoubted advantage that significantly improves the maintenance and technical assistance aspects in critical installations.

DC POLARITY GROUNDED SENSOR

There is a fixed-threshold sensor (about 15mA, referring to the system's output terminals) that detects possible loss of insulation of the output poles and batteries present in the system. This sensor is NOT similar to an INSULATION CONTROL instrument but is provided to give an initial indication of any abnormality. The circuit detects the loss of insulation of the **POSITIVE** pole or the **NEGATIVE** pole differentiated.

From HMI you can activate and deactivate the function

AC/DC - IGBT - CHOPPER

It consists of a High Frequency regulator in configuration IGBT STEP-DOWN with PWM technology control.

FLOATING CHARGE

This recharge has two different phases:

- Phase 1: the current is constant and the voltage increases
- Phase 2: The current decreases and the voltage is constant.

When the recharging current falls below a certain value, the batteries are considered charged and the cycle is over. In this situation the output goes to the floating value which is the minimum value necessary for correct recharging maintenance battery.

WIRING

- Power cables AC and DC sections = FS17 CPR Cca-s3,d1,a3
- Signaling and control cables = FRO-HP CPR Cca-s3,d1,a3
- FLAT CABLE = Flame Classification FT1,FT2
- Data transmission cables = Cavo RJ45 - CAT5 FTP

ALARMS RELAY CARD

There is a board consisting of 7 alarm relays with SPDT type contact shown on removable and polarized printed circuit terminals. The electrical contacts have a range of 5Amp to 250Vac.

There are three fixed alarms respectively:

- **AC MAINS PRESENCE** - wired in positive logic
- **GENERAL FAILURE** - wired in positive logic
- **LOW BATTERY VOLTAGE**

While it is possible to configure the remaining 4 from the HMI. From HMI you can configure 4 alarms depending on the menu on HMI.

INPUT TRANSFORMER

The power transformer is made with a core of first choice laminations (optional the solution with oriented crystals) and an electrostatic screen between primary and secondary. It produces the reduction of the input voltage to the most appropriate value for the operation of the conversion system and insulation from the network (4kV). The transformer is made with class F supports and insulators (155 ° C) while the windings are in electrolytic copper class H double insulation (220 ° C). There is an electrostatic shield connected to earth between primary and secondary. The transformers comply with the Standard CEI EN 61558-2-4-file 4971 classification CEI 96-7.

BATTERY EFFICIENCY ANALYSIS "B.E.A."

Advanced feature that determines the state of efficiency of the battery through the mathematical comparison between the real trend of the voltage during the discharge of the battery and the theoretical curve based on **Peukert's law**.

TITANIUM PLUS 1R-SCR

DC POWER SUPPLY SYSTEMS



APPLICATIONS

- Oil & Gas
- Energy production and distribution
- Process controls
- Transportation
- Safety
- Telecommunications
- Tertiary

STANDARD FUNCTIONS

- AC mcb with cont. aux.
- Floating charge
- Boost charge
- Manual charge
- Temperature compensation
- Test battery function
- BEA function (Battery Efficiency Analysis)
- DC earth pole sensor
- Relay alarm card

SINGLE LINE DIAGRAM

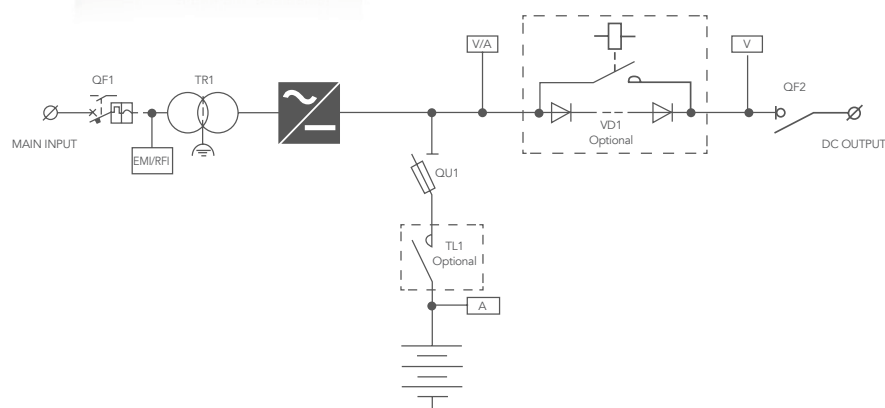

SINGLE BRANCH Rectifier - SCR type

TITANIUM PLUS 1R-SCR is a Single Branch rectifier, provided with a single SCR thyristor-based AC/DC conversion unit which supplies the loads and simultaneously charges the battery. The rectifier is assembled in an industrial cabinet 2000mm height and can be supplied with sealed or vented Lead Acid and NiCd batteries. The AC/DC conversion unit is removable, in order to improve the efficiency and obtain an high MTBF with an extremely low MTTR.

Further, the rectifier is provided with an input insulation transformer, in order to contain the output voltage ripple, and features our latest HMI, including a touchscreen display 7" with integrated web server and MODBUS TCP/IP communication protocol.

MAIN FEATURES

- Input insulation transformer at mains frequency, with an electrostatic shield
- Bridge rectifier Chopper on REMOVABLE UNITS
- Control type: High frequency PWM
- System control with industrial PLC on REMOVABLE UNITS
- Charge curve for each type of battery (AGM - GEL - PB - NI-CD)
- 3 charging levels including manual charging complete with safety timer
- HMI - Digital control panel with touchscreen display 7" with integrated Web server
- High efficiency and reliability
- Easy maintenance with access from the front and removable power units
- Extended frequency range accepted as input
- Low residual ripple as output and on batteries (RIPPLE)
- Low residual ripple as output and on batteries (RIPPLE)
- BEA Function (Battery Efficiency Analysis)
- DC polarity on the ground sensor
- MODBUS TCP/IP communication (slave – server)
- Alarm cards with 3 fixed relays and 4 completely programmable by user
- Temperature compensation with PT100 sensor and correction coefficient (Vel/°C) settable by the user

COMMUNICATION (Modbus slave TCP/IP)

Individual word for electrical parameters:

- Output voltage to loads
- Output current to loads
- Current battery charge
- Battery temperature

DoubleWord alarms:

- Showing all the signals present on the HMI

SIGNALS AND MEASURES

- AC Mains ON
- AC/DC ON
- Rectifier High voltage output
- Rectifier Low voltage output
- Floating charge
- Boost charge (x)
- Manual charge (x)
- Active temperature compensation (x)
- Battery charging current limitation ON
- Negative grounded pole
- Output overload
- Battery test in progress
- Battery test failed
- Operating from batteries
- Low battery voltage
- End of battery drain
- High battery temperature (x)
- AC input MCB OFF AC

(x) HMI - enable function

HMI PANEL

- Output voltage
- Output current
- Current battery charge
- Battery temperature



TITANIUM PLUS 1R-SCR

GENERAL	BATTERY	Suited for sealed (VRLA) or vented Lead Acid or NiCd battery			
	CHARGING CHARACTERISTICS	IU (according to DIN 41773) floating, boost and manual charging			
OUTPUT	NOMINAL VOLTAGE (V)	24	48	110	220
	CURRENT RANGE	60 ÷ 500 A		60 ÷ 250 A	
	MAXIMUM POWER (W)	12000	24000	55000	55000
	RIPPLE NOISE (RMS)	1%			
	V _{out} SETTING RANGE	+/- 5%			
	VOLTAGE STABILITY	+/- 1%			
	V _{in} VARIATION SETTING	+/- 1%			
	LOAD VARIATION SETTING	+/- 1%			
INPUT	START-UP TIME	10 sec.			
	VOLTAGE RANGE	three-phase 400Vac ±10%			
	INPUT FREQUENCY	50 ÷ 60 +/-5%			
	EFFICIENCY (Typ.)	≥ 90 %			
PROTECTIONS	I7O INSULATION	4kV by transformer			
	INPUT	Automatic circuit breaker			
	BATTERY	Fuses			
	OUTPUT	Switch			
	OVERLOAD	<120% for 20 minuti, >150% for 5 secondi			
	CURRENT CURVE	Constant			
	OVERVOLTAGE	+ 10% Vn			
	UNDERVOLTAGE	- 50% Vn			
	OVERTEMPERATURE	Shut down. Automatic restart after temperature reset			
	ALARMS	ALARM CARD WITH N.3 RELAYS SPDT 5A/250VAC	AC Mains presence, General Failure, Low Battery voltage		
N. 4 USER PROGRAMMABLE RELAYS VIA HMI PANEL					
AMBIENT	OPERATING TEMPERATURE	-10+40°C			
	OPERATING HUMIDITY	< 95% without condensation			
	STORAGE TEMPERATURE	-20+70°C			
STANDARDS	NOISE LEVEL	according EN50091 < 60 dBA (typical value with forced ventilation in operation)			
	MARKING	CE			
	PROTECTION DEGREE	IEC 60529			
	EMC	EN 61000-6-2 EN 61000-6-4			
	STATIC CONVERTERS	EN 60146			
	DC-UPS (performance, routine test, requirements)	IEC 62040-5-3			
PROTECTION DEGREE (closed door)	IP31 standard, others on demand				
COLOR	RAL 7035 cabinet - RAL7012 roof and base				

* Relay normally operating in positive safety

The **SYSTEM CONTROL** is now based on an expandable Industrial PLC, characterized therefore by a very high reliability as well as by a considerable flexibility, it allows to satisfy a greater number of technical needs and consequent applications. This section, which constitutes the “intelligent” heart of our system, is now made in a special drawer located on the inside of the main door of the cabinet and **FULLY REMOVABLE** thanks to the presence of a polarized connector. This solution introduces a very important advantage, in fact it is possible to replace this assembly while hot, with the machine running, without turning off the system. This is possible as the AC / DC conversion units recognize the loss of communication with the drawer and set themselves up in **AUTOMATIC SAFE MODE**, actually working independently and guaranteeing continuity of operation. Once the drawer has been replaced and the connection re-established, the AC/DC units will return to operate under the automatic control of the PLC, resuming normal and complete operation. The HMI (Human Machine Interface) system has also been renewed, which now includes a touch panel, capacitive, 7 “with excellent visibility characteristics, mechanical resistance to wear and connectivity with the outside world. Finally, a great deal of space was reserved for **REMOTE CONNECTION**, in fact now it is possible to control, parameterize and manage these systems in absolute safety through the **INTERNET** network thanks to the standard presence of the **WEB SERVER** function. This has an undoubted advantage that significantly improves the maintenance and technical assistance aspects in critical installations.

DC POLARITY GROUNDED SENSOR

There is a fixed-threshold sensor (about 15mA, referring to the system's output terminals) that detects possible loss of insulation of the output poles and batteries present in the system. This sensor is **NOT similar** to an **INSULATION CONTROL** instrument but is provided to give an initial indication of any abnormality. The circuit detects the loss of insulation of the **POSITIVE** pole or the **NEGATIVE** pole differentiated. From HMI you can activate and deactivate the function.

AC/DC - THYRISTOR

It consists of a rectifier bridge in a fully controlled configuration.

FLOATING CHARGE

This recharge has two different phases:

- Phase 1: the current is constant and the voltage increases
 - Phase 2: the current decreases and the voltage is constant
- When the recharging current falls below a certain value, the batteries are considered charged and the cycle is over. In this situation the output goes to the floating value which is the minimum value necessary for correct recharging maintenance battery.

WIRING

- Power cables AC and DC sections = FS17 CPR Cca-s3,d1,a3
- Signaling and control cables = FRO-HP CPR Cca-s3,d1,a3
- FLAT CABLE = Flame Classification FT1,FT2
- Data transmission cables = Cavo RJ45 - CAT5 FTP

ALARMS RELAY CARD

There is a board consisting of 7 alarm relays with SPDT type contact shown on removable and polarized printed circuit terminals. The electrical contacts have a range of 5Amp to 250Vac. There are three fixed alarms respectively:

- **AC MAINS PRESENCE** - wired in positive logic
- **GENERAL FAILURE** - wired in positive logic
- **LOW BATTERY VOLTAGE**

While it is possible to configure the remaining 4 from the HMI. From HMI you can configure 4 alarms depending on the menu on HMI.

INPUT TRANSFORMER

The power transformer is made with a core of first choice laminations (optional the solution with oriented crystals) and an electrostatic screen between primary and secondary. It produces the reduction of the input voltage to the most appropriate value for the operation of the conversion system and insulation from the network (4kV). The transformer is made with class F supports and insulators (155 °C) while the windings are in electrolytic copper class H double insulation (220 °C). There is an electrostatic shield connected to earth between primary and secondary. The transformers comply with the Standard CEI EN 61558-2-4-file 4971 classification CEI 96-7.

BATTERY EFFICIENCY ANALYSIS “B.E.A.”

Advanced feature that determines the state of efficiency of the battery through the mathematical comparison between the real trend of the voltage during the discharge of the battery and the theoretical curve based on **Peukert's law**.

TITANIUM PLUS 2RP-CH

DC POWER SUPPLY SYSTEMS



APPLICATIONS

- Oil & Gas
- Energy production and distribution
- Process controls
- Transportation
- Safety
- Telecommunications
- Tertiary

STANDARD FUNCTIONS

- AC mcb with cont. aux.
- Floating charge
- Boost charge
- Manual charge
- Temperature compensation
- Test battery function
- **BEA** function (Battery Efficiency Analysis)
- DC earth pole sensor
- Relay alarm card

SINGLE LINE DIAGRAM

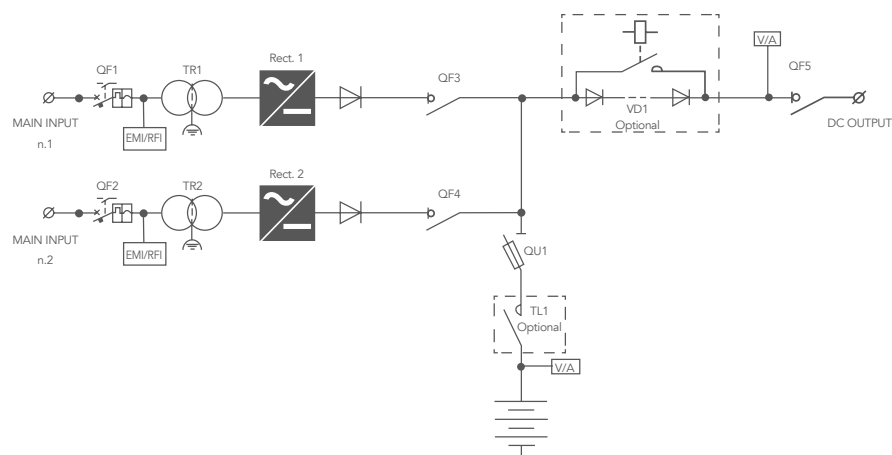

DOUBLE BRANCH Rectifier PARALLEL - IGBT type

TITANIUM PLUS 2RP-CH is a Double Branch Parallel rectifier, provided with two independent IGBT-based AC/DC conversion units in redundant (or power) parallel configuration, that supplies the loads and simultaneously charges the battery. The rectifier is assembled in an industrial cabinet 2000mm height and can be supplied with sealed or vented Lead Acid and NiCd batteries. The AC/DC conversion units are removable, in order to improve the efficiency and obtain an high MTBF with an extremely low MTTR. Further, the rectifier is provided with two input insulation transformers (one for each branch), in order to contain the output voltage ripple, and features our latest HMI, including a touchscreen display 7" with integrated web server and MODBUS TCP/IP communication protocol.

MAIN FEATURES

- Input insulation transformer at mains frequency, with an electrostatic shield
- Bridge rectifier Chopper **IGBT on REMOVABLE UNITS**
- Control type: High frequency PWM
- System control with industrial **PLC on REMOVABLE UNITS**
- Charge curve for each type of battery (AGM - GEL - PB - NICD) 3 charging levels including manual charging complete
- HMI - Digital control panel with touchscreen display 7" with integrated Web server
- High efficiency and reliability
- Easy maintenance with access from the front and removable power units
- Extended frequency range accepted as input
- Low residual ripple as output and on batteries (RIPPLE)
- Automatic and manual battery test (performing a true discharge battery test)
- **BEA** Function (Battery Efficiency Analysis)
- DC polarity on the ground sensor
- MODBUS TCP/IP communication (slave – server)
- Alarm cards with 3 fixed relays and 4 completely programmable by user
- Temperature compensation with PT100 sensor and correction coefficient (Vel/°C) settable by the user

COMMUNICATION (Modbus slave TCP/IP)

Individual word for electrical parameters:

- Output voltage to loads
- Output current to loads
- Battery voltage
- Current battery charge
- Battery temperature

DoubleWord alarms:

- Showing all the signals present on the HMI

SIGNALS AND MEASURES

- AC Mains ON
- AC/DC 1 ON
- AC/DC 2 ON
- AC/DC load output voltage High/Low
- Battery load output voltage High/Low
- Floating charge
- Boost charge (x)
- Manual charge (x)
- Active temperature compensation (x)
- Battery charging current limitation ON
- Positive grounded pole
- Negative grounded pole
- Output overload
- Battery test in progress
- Battery test failed
- Operating from batteries
- Low battery voltage
- End of battery drain
- High battery temperature (x)
- AC input MCB OFF AC

(x) HMI - enable function

HMI PANEL

- Output voltage
- Output current
- Battery voltage
- Current battery charge
- Battery temperature



TITANIUM PLUS 2RP-CH

GENERAL	BATTERY	Suited for sealed (VRLA) or vented Lead Acid or NiCd battery			
	CHARGING CHARACTERISTICS	IU (according to DIN 41773) floating, boost and manual charging			
OUTPUT	NOMINAL VOLTAGE (V)	24	48	110	
	CURRENT RANGE	2 x 10 ÷ 100 A			
	MAXIMUM POWER (W)	2 x 2400	2 x 4800	2 x 11000	
	RIPPLE NOISE (RMS)	1%			
	V _{out} SETTING RANGE	+/- 5%			
	VOLTAGE STABILITY	+/- 1%			
	V _{in} VARIATION SETTING	+/- 1%			
	LOAD VARIATION SETTING	+/- 1%			
	START-UP TIME	2 sec.			
	INPUT	VOLTAGE RANGE	single-phase 230 Vac +/- 10% or three-phase 400Vac +/- 10%		
INPUT FREQUENCY		50 ÷ 60 +/- 7%			
EFFICIENCY (Typ.)		≥ 90 %			
I70 INSULATION		4kV by transformer			
PROTECTIONS	INPUT (for each branch)	Automatic circuit breaker			
	BATTERY	Fuses			
	OUTPUT	Switch			
	OVERLOAD	2In x 5mS Shut down for 250mS - restart aut.			
	CURRENT CURVE	Constant			
	OVERVOLTAGE	+ 10% V _n			
	UNDERVOLTAGE	- 50% V _n			
	OVERTEMPERATURE	Shut down. Automatic restart after temperature reset			
	ALARMS	ALARM CARD CON N.3 RELAYS SPDT 5A/250VAC	AC Mains presence, General Failure, Low Battery voltage		
		N. 4 USER PROGRAMMABLE RELAYS VIA HMI PANEL			
AMBIENT	OPERATING TEMPERATURE	-10+40°C			
	OPERATING HUMIDITY	< 95% without condensation			
	STORAGE TEMPERATURE	-20+70°C			
	NOISE LEVEL	according EN50091 < 60 dBA (typical value with forced ventilation in operation)			
STANDARDS	MARKING	CE			
	PROTECTION DEGREE	IEC 60529			
	EMC	EN 61000-6-2 EN 61000-6-4			
	STATIC CONVERTERS	EN 60146			
	DC-UPS (performance, routine test, requirements)	IEC 62040-5-3			
PROTECTION DEGREE (closed door)		IP31 standard, others on demand			
COLOR		RAL 7035 cabinet - RAL7012 roof and base			

The **SYSTEM CONTROL** is now based on an expandable Industrial PLC, characterized therefore by a very high reliability as well as by a considerable flexibility, it allows to satisfy a greater number of technical needs and consequent applications. This section, which constitutes the "intelligent" heart of our system, is now made in a special drawer located on the inside of the main door of the cabinet and **FULLY REMOVABLE** thanks to the presence of a polarized connector. This solution introduces a very important advantage, in fact it is possible to replace this assembly while hot, with the machine running, without turning off the system. This is possible as the AC/DC conversion units recognize the loss of communication with the drawer and set themselves up in **AUTOMATIC SAFE MODE**, actually working independently and guaranteeing continuity of operation. Once the drawer has been replaced and the connection re-established, the AC/DC units will return to operate under the automatic control of the PLC, resuming normal and complete operation. The HMI (Human Machine Interface) system has also been renewed, which now includes a touch panel, capacitive, 7" with excellent visibility characteristics, mechanical resistance to wear and connectivity with the outside world. Finally, a great deal of space was reserved for **REMOTE CONNECTION**, in fact now it is possible to control, parameterize and manage these systems in absolute safety through the **INTERNET** network thanks to the standard presence of the **WEB SERVER** function. This has an undoubted advantage that significantly improves the maintenance and technical assistance aspects in critical installations.

DC POLARITY GROUNDED SENSOR

There is a fixed-threshold sensor (about 15mA, referring to the system's output terminals) that detects possible loss of insulation of the output poles and batteries present in the system. This sensor is **NOT similar** to an **INSULATION CONTROL** instrument but is provided to give an initial indication of any abnormality. The circuit detects the loss of insulation of the **POSITIVE** pole or the **NEGATIVE** pole differentiated.

From HMI you can activate and deactivate the function.

AC/DC - IGBT - CHOPPER

It consists of a High Frequency regulator in configuration IGBT STEP-DOWN with PWM technology control.

FLOATING CHARGE

This recharge has two different phases:

- Phase 1: the current is constant and the voltage increases
 - Phase 2: The current decreases and the voltage is constant.
- When the recharging current falls below a certain value, the batteries are considered charged and the cycle is over. In this situation the output goes to the floating value which is the minimum value necessary for correct recharging maintenance battery.

WIRING

- Power cables AC and DC sections = FS17 CPR Cca-s3,d1,a3
- Signaling and control cables = FRO-HP CPR Cca-s3,d1,a3
- FLAT CABLE = Flame Classification FT1,FT2
- Data transmission cables = Cavo RJ45 - CAT5 FTP

ALARMS RELAY CARD

There is a board consisting of 7 alarm relays with SPDT type contact shown on removable and polarized printed circuit terminals. The electrical contacts have a range of 5Amp to 250Vac.

There are three fixed alarms respectively:

- **AC MAINS PRESENCE** - wired in positive logic
- **GENERAL FAILURE** - wired in positive logic
- **LOW BATTERY VOLTAGE**

While it is possible to configure the remaining 4 from the HMI. From HMI you can configure 4 alarms depending on the menu on HMI.

INPUT TRANSFORMER

The power transformer is made with a core of first choice laminations (optional the solution with oriented crystals) and an electrostatic screen between primary and secondary. It produces the reduction of the input voltage to the most appropriate value for the operation of the conversion system and insulation from the network (4kV). The transformer is made with class F supports and insulators (155 ° C) while the windings are in electrolytic copper class H double insulation (220 ° C). There is an electrostatic shield connected to earth between primary and secondary. The transformers comply with the Standard CEI EN 61558-2-4-file 4971 classification CEI 96-7.

BATTERY EFFICIENCY ANALYSIS "B.E.A."

Advanced feature that determines the state of efficiency of the battery through the mathematical comparison between the real trend of the voltage during the discharge of the battery and the theoretical curve based on **Peukert's law**.

* Relay normally operating in positive safety

TITANIUM PLUS 2RP-SCR

DC POWER SUPPLY SYSTEMS



APPLICATIONS

- Oil & Gas
- Energy production and distribution
- Process controls
- Transportation
- Safety
- Telecommunications
- Tertiary

STANDARD FUNCTIONS

- AC mcb with cont. aux.
- Floating charge
- Boost charge
- Manual charge
- Temperature compensation
- Test battery function
- **BEA** function (Battery Efficiency Analysis)
- DC earth pole sensor
- Relay alarm card

SINGLE LINE DIAGRAM

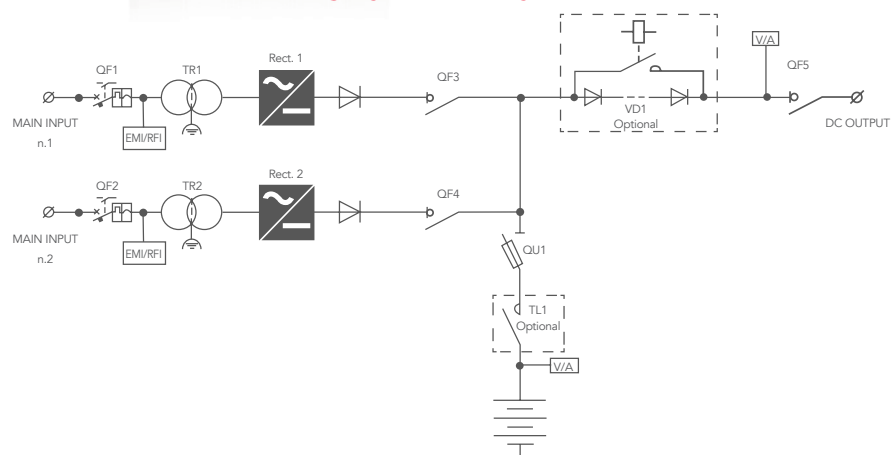

DOUBLE BRANCH Rectifier PARALLEL - SCR type

TITANIUM PLUS 2RP-SCR is a Double Branch Parallel rectifier, provided with two independent SCR thyristor-based AC/DC conversion units in redundant (or power) parallel configuration, that supplies the loads and simultaneously charges the battery. The rectifier is assembled in an industrial cabinet 2000mm height and can be supplied with sealed or vented Lead Acid and NiCd batteries. The AC/DC conversion units are removable, in order to improve the efficiency and obtain an high MTBF with an extremely low MTTR. Further, the rectifier is provided with two input insulation transformers (one for each branch), in order to contain the output voltage ripple, and features our latest HMI, including a touchscreen display 7" with integrated web server and MODBUS TCP/IP communication protocol.

MAIN FEATURES

- Input insulation transformer at mains frequency, with an electrostatic shield
- SCR Power Bridge Rectifier Total-controlled on REMOVABLE UNITS
- Control type: High frequency PWM
- System control with industrial PLC on REMOVABLE UNITS
- Charge curve for each type of battery (AGM - GEL - PB - NICD) 3 charging levels including manual charging complete with safety timer
- HMI - Digital control panel with touchscreen display 7" with integrated Web server
- High efficiency and reliability
- Easy maintenance with access from the front and removable power units
- Extended frequency range accepted as input
- Low residual ripple as output and on batteries (RIPPLE)
- Automatic and manual battery test (performing a true discharge battery test)
- **BEA** Function (Battery Efficiency Analysis)
- DC polarity on the ground sensor
- MODBUS TCP/IP communication (slave – server)
- Alarm cards with 3 fixed relays and 4 completely programmable by user
- Temperature compensation with PT100 sensor and correction coefficient (Vel/°C) settable by the user

COMMUNICATION (Modbus slave TCP/IP)

Individual word for electrical parameters:

- Output voltage to loads
- Output current to loads
- Battery voltage
- Current battery charge
- Battery temperature

HMI PANEL

- Output voltage
- Output current
- Battery voltage
- Current battery charge
- Battery temperature

SIGNALS AND MEASURES

- AC Mains ON
- AC/DC 1 ON
- AC/DC 2 ON
- AC/DC load output voltage HIGH/LOW
- Battery load output voltage HIGH/LOW
- Floating charge
- Boost charge (x)
- Manual charge (x)
- Active temperature compensation (x)
- Battery charging current limitation ON
- Positive grounded pole
- Negative grounded pole
- Output overload
- Battery test in progress
- Battery test failed
- Operating from batteries
- Low battery voltage
- End of battery drain
- High battery temperature (x)
- AC input MCB OFF AC

DoubleWord alarms:

- Showing all the signals present on the HMI

(x) HMI - enable function



TITANIUM PLUS 2RP-SCR

GENERAL	BATTERY	Suited for sealed (VRLA) or vented Lead Acid or NiCd battery				
	CHARGING CHARACTERISTICS	IU (according to DIN 41773) floating, boost and manual charging				
OUTPUT	NOMINAL VOLTAGE (V)	24	48	110	220	
	CURRENT RANGE	2 x 60 ÷ 500 A			2 x 60 ÷ 250 A	
	MAXIMUM POWER (W)	2 x 12000	2 x 24000	2 x 55000	2 x 55000	
	RIPPLE NOISE (RMS)	1%				
	Vout SETTING RANGE	+/- 5%				
	VOLTAGE STABILITY	+/- 1%				
	Vin VARIATION SETTING	+/- 1%				
	LOAD VARIATION SETTING	+/- 1%				
	START-UP TIME	10 sec.				
	INPUT	VOLTAGE RANGE	three-phase 400Vac ±10%			
INPUT FREQUENCY		50 ÷ 60 +/-5%				
EFFICIENCY (Typ.)		≥ 90 %				
I70 INSULATION		4kV by transformer				
PROTECTIONS	INPUT (per ciascun ramo)	Automatic circuit breaker				
	BATTERY	Fuses				
	OUTPUT	Switch				
	OVERLOAD	<120% for 20 minuti, >150% for 5 secondi				
	CURRENT CURVE	Constant				
	OVERVOLTAGE	+ 10% Vn				
	UNDERVOLTAGE	- 50% Vn				
	OVERTEMPERATURE	Shut down. Automatic restart after temperature reset				
	ALARMS	ALARM CARD WITH N.3 RELAYS SPDT 5A/250VAC	AC Mains presence, General Failure, Low Battery voltage			
		N. 4 USER PROGRAMMABLE RELAYS VIA HMI PANEL				
AMBIENT	OPERATING TEMPERATURE	-10+40°C				
	OPERATING HUMIDITY	< 95% without condensation				
	STORAGE TEMPERATURE	-20+70°C				
	NOISE LEVEL	according EN50091 < 60 dBA (typical value with forced ventilation in operation)				
STANDARDS	MARKING	CE				
	PROTECTION DEGREE	IEC 60529				
	EMC	EN 61000-6-2 EN 61000-6-4				
	STATIC CONVERTERS	EN 60146				
	DC-UPS (performance, routine test, requirements)	IEC 62040-5-3				
PROTECTION DEGREE (closed door)		IP31 standard, others on demand				
COLOR		RAL 7035 cabinet - RAL7012 roof and base				

The **SYSTEM CONTROL** is now based on an expandable Industrial PLC, characterized therefore by a very high reliability as well as by a considerable flexibility, it allows to satisfy a greater number of technical needs and consequent applications. This section, which constitutes the "intelligent" heart of our system, is now made in a special drawer located on the inside of the main door of the cabinet and **FULLY REMOVABLE** thanks to the presence of a polarized connector. This solution introduces a very important advantage, in fact it is possible to replace this assembly while hot, with the machine running, without turning off the system. This is possible as the AC / DC conversion units recognize the loss of communication with the drawer and set themselves up in **AUTOMATIC SAFE MODE**, actually working independently and guaranteeing continuity of operation. Once the drawer has been replaced and the connection re-established, the AC/DC units will return to operate under the automatic control of the PLC, resuming normal and complete operation. The HMI (Human Machine Interface) system has also been renewed, which now includes a touch panel, capacitive, 7 "with excellent visibility characteristics, mechanical resistance to wear and connectivity with the outside world. Finally, a great deal of space was reserved for **REMOTE CONNECTION**, in fact now it is possible to control, parameterize and manage these systems in absolute safety through the **INTERNET** network thanks to the standard presence of the WEB SERVER function. This has an undoubted advantage that significantly improves the maintenance and technical assistance aspects in critical installations.

DC POLARITY GROUNDED SENSOR

There is a fixed-threshold sensor (about 15mA, referring to the system's output terminals) that detects possible loss of insulation of the output poles and batteries present in the system. This sensor is **NOT similar** to an **INSULATION CONTROL** instrument but is provided to give an initial indication of any abnormality. The circuit detects the loss of insulation of the **POSITIVE** pole or the **NEGATIVE** pole differentiated. From HMI you can activate and deactivate the function.

AC/DC - THYRISTOR

It consists of a rectifier bridge in a fully controlled configuration.

FLOATING CHARGE

This recharge has two different phases:

- Phase 1: the current is constant and the voltage increases
- Phase 2: the current decreases and the voltage is constant. When the recharging current falls below a certain value, the batteries are considered charged and the cycle is over. In this situation the output goes to the floating value which is the minimum value necessary for correct recharging maintenance battery.

WIRING

- Power cables AC and DC sections = FS17 CPR Cca-s3,d1,a3
- Signaling and control cables = FRO-HP CPR Cca-s3,d1,a3
- FLAT CABLE = Flame Classification FT1,FT2
- Data transmission cables = Cavo RJ45 - CAT5 FTP

ALARMS RELAY CARD

There is a board consisting of 7 alarm relays with SPDT type contact shown on removable and polarized printed circuit terminals. The electrical contacts have a range of 5Amp to 250Vac.

There are three fixed alarms respectively:

- **AC MAINS PRESENCE** - wired in positive logic
- **GENERAL FAILURE** - wired in positive logic
- **LOW BATTERY VOLTAGE**

While it is possible to configure the remaining 4 from the HMI. From HMI you can configure 4 alarms depending on the menu on HMI.

INPUT TRANSFORMER

The power transformer is made with a core of first choice laminations (optional the solution with oriented crystals) and an electrostatic screen between primary and secondary. It produces the reduction of the input voltage to the most appropriate value for the operation of the conversion system and insulation from the network (4kV). The transformer is made with class F supports and insulators (155 ° C) while the windings are in electrolytic copper class H double insulation (220 ° C). There is an electrostatic shield connected to earth between primary and secondary. The transformers comply with the Standard CEI EN 61558-2-4-file 4971 classification CEI 96-7.

BATTERY EFFICIENCY ANALYSIS "B.E.A."

Advanced feature that determines the state of efficiency of the battery through the mathematical comparison between the real trend of the voltage during the discharge of the battery and the theoretical curve based on **Peukert's law**.

* Relay normally operating in positive safety

TITANIUM PLUS 2R-CH

DC POWER SUPPLY SYSTEMS



APPLICATIONS

- Oil & Gas
- Energy production and distribution
- Process controls
- Transportation
- Safety
- Telecommunications
- Tertiary

DOUBLE BRANCH Rectifier - IGBT type

TITANIUM PLUS 2R-IGBT is a Double Branch rectifier, provided with two independent IGBT-based AC/DC conversion units, one powering the DC loads with stabilized voltage and the other one dedicated to charge the battery. The rectifier is assembled in an industrial cabinet 2000mm height and can be supplied with sealed or vented Lead Acid and NiCd batteries. The AC/DC conversion units are removable, in order to improve the efficiency and obtain an high MTBF with an extremely low MTTR. Further, the rectifier is provided with two input insulation transformers (one for each branch), in order to contain the output voltage ripple, and features our latest HMI, including a touchscreen display 7" with integrated web server and MODBUS TCP/IP communication protocol.

MAIN FEATURES

- Input insulation transformer at mains frequency, with an electrostatic shield
- Bridge rectifier Chopper **IGBT on REMOVABLE UNITS**
- Control type: **High frequency PWM**
- System control with industrial **PLC on REMOVABLE UNITS**
- Charge curve for each type of battery (AGM - GEL - PB - NICD)
- 3 charging levels including manual charging complete with safety timer
- HMI - Digital control panel with touchscreen display 7" with integrated Web server • High efficiency and reliability
- Easy maintenance with access from the front and removable power units
- Extended frequency range accepted as input
- Low residual ripple as output and on batteries (RIPPLE)
- Automatic and manual battery test (performing a true discharge battery test)
- **BEA** Function (Battery Efficiency Analysis)
- DC polarity on the ground sensor
- MODBUS TCP/IP communication (slave – server)
- Alarm cards with 3 fixed relays and 4 completely programmable by user
- Temperature compensation with PT100 sensor and correction coefficient (Vel/°C) settable by the user

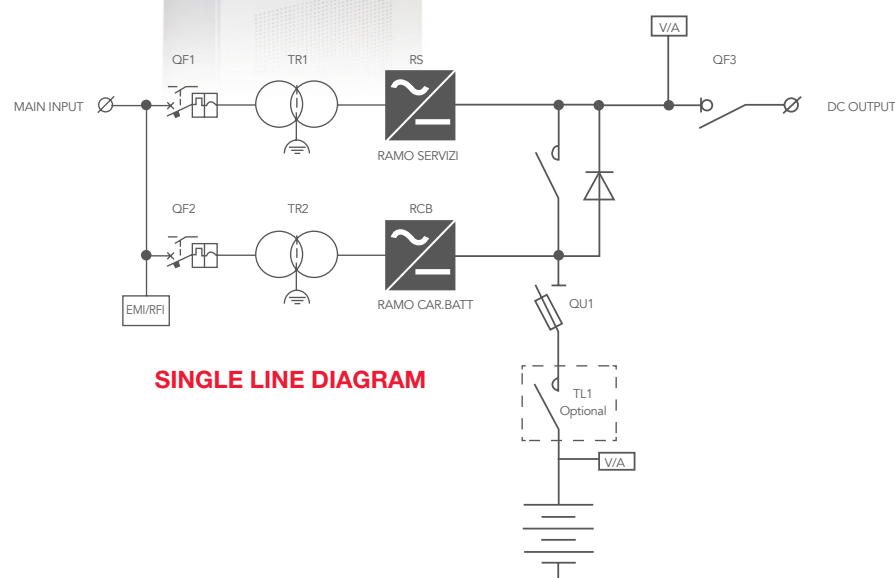

SINGLE LINE DIAGRAM



STANDARD FUNCTIONS

- AC mcb with cont. aux.

BATTERY BRANCH - RCB

- Floating charge
- Boost charge
- Manual charge
- Emergency operating voltage
- Temperature compensation
- Test battery function
- **BEA** function (Battery Efficiency Analysis)

SERVICE BRANCH - RS

- Normal operating voltage
- Emergency operating voltage

SYSTEM

- Poweboost function
- Relay alarm card
- DC earth pole sensor

COMMUNICATION (Modbus slave TCP/IP)

Individual word for electrical parameters:

- Output voltage to loads
- Output current to loads
- Battery voltage
- Current battery charge
- Battery temperature

DoubleWord alarms:

- Showing all the signals present on the HMI

SIGNALS AND MEASURES

- AC Mains ON
- AC/DC RS ON
- AC/DC RCB ON
- RS Rectifier High voltage output
- RCB Rectifier High voltage output
- RS Rectifier Low voltage output
- RCB Rectifier Low voltage output
- RCB Floating charge
- RCB Boost charge (x)
- RCB Manual charge (x)
- Active temperature compensation (x)
- Battery charging current limitation ON
- Positive grounded pole
- Negative grounded pole
- Output overload
- Battery test in progress
- Battery test failed
- Operating from batteries
- Low battery voltage
- End of battery drain
- High battery temperature (x)
- AC input MCB OFF AC

(x) HMI - enable function

HMI PANEL

- Output voltage
- Output current
- Battery voltage
- Current battery charge
- Battery temperature

TITANIUM PLUS 2R-CH

GENERAL	BATTERY	Suited for sealed (VRLA) or vented Lead Acid or NiCd battery			
	CHARGING CHARACTERISTICS	IU (according to DIN 41773) floating, boost and manual charging			
	NOMINAL VOLTAGE (V)	24	48	110	
OUTPUT	CURRENT RANGE	10 ÷ 100 A			
	MAXIMUM POWER (W)	2400	4800	11000	
	RIPPLE NOISE (RMS)	1%			
	Vout SETTING RANGE	+/- 5%			
	VOLTAGE STABILITY	+/- 1%			
	Vin VARIATION SETTING	+/- 1%			
	LOAD VARIATION SETTING	+/- 1%			
	START-UP TIME	2 sec.			
	INPUT	VOLTAGE RANGE	single-phase 230 Vac +/- 10% or three-phase 400Vac +/- 10%		
		INPUT FREQUENCY	50 ÷ 60 +/-7%		
EFFICIENCY (Typ.)		≥ 90 %			
I7O INSULATION		4kV by transformer			
PROTECTIONS	INPUT	Automatic circuit breaker			
	BATTERY	Fuses			
	OUTPUT	Switch			
	OVERLOAD	2In x 5mS Shut down for 250mS - restart aut.			
	CURRENT CURVE	Constant			
	OVERVOLTAGE	+ 10% Vn			
	UNDERVOLTAGE	- 50% Vn			
OVERTEMPERATURE	Shut down. Automatic restart after temperature reset				
ALARMS	ALARM CARD WITH N.3 RELAYS SPDT 5A/ 250VAC	AC Mains presence, General Failure, Low Battery voltage			
	N. 4 USER PROGRAMMABLE RELAYS VIA HMI PANEL				
AMBIENT	OPERATING TEMPERATURE	-10+40°C			
	OPERATING HUMIDITY	< 95% without condensation			
	STORAGE TEMPERATURE	-20+70°C			
	NOISE LEVEL	according EN50091 < 60 dBA (typical value with forced ventilation in operation)			
STANDARDS	MARKING	CE			
	PROTECTION DEGREE	IEC 60529			
	EMC	EN 61000-6-2 EN 61000-6-4			
	STATIC CONVERTERS	EN 60146			
	DC-UPS (performance, routine test, requirements)	IEC 62040-5-3			
PROTECTION DEGREE (closed door)	IP31 standard, others on demand				
COLOR	RAL 7035 cabinet - RAL7012 roof and base				

* Relay normally operating in positive safety

The **SYSTEM CONTROL** is now based on an expandable Industrial PLC, characterized therefore by a very high reliability as well as by a considerable flexibility, it allows to satisfy a greater number of technical needs and consequent applications. This section, which constitutes the “intelligent” heart of our system, is now made in a special drawer located on the inside of the main door of the cabinet and **FULLY REMOVABLE** thanks to the presence of a polarized connector. This solution introduces a very important advantage, in fact it is possible to replace this assembly while hot, with the machine running, without turning off the system.

This is possible as the AC / DC conversion units recognize the loss of communication with the drawer and set themselves up in **AUTOMATIC SAFE MODE**, actually working independently and guaranteeing continuity of operation.

Once the drawer has been replaced and the connection re-established, the **AC/DC** units will return to operate under the automatic control of the PLC, resuming normal and complete operation. The HMI (Human Machine Interface) system has also been renewed, which now includes a touch panel, capacitive, 7 "with excellent visibility characteristics, mechanical resistance to wear and connectivity with the outside world. Finally, a great deal of space was reserved for **REMOTE CONNECTION**, in fact now it is possible to control, parameterize and manage these systems in absolute safety through the **INTERNET** network thanks to the standard presence of the **WEB SERVER** function.

This has an undoubted advantage that significantly improves the maintenance and technical assistance aspects in critical installations.

DC POLARITY GROUNDED SENSOR

There is a fixed-threshold sensor (about 15mA, referring to the system's output terminals) that detects possible loss of insulation of the output poles and batteries present in the system.

This sensor is **NOT similar** to an **INSULATION CONTROL** instrument but is provided to give an initial indication of any abnormality. The circuit detects the loss of insulation of the **POSITIVE** pole or the **NEGATIVE** pole differentiated. From HMI you can activate and deactivate the function.

AC/DC - IGBT - CHOPPER

It consists of a High Frequency regulator in configuration IGBT STEP-DOWN with PWM technology control.

FLOATING CHARGE

This recharge has two different phases:

- Phase 1: the current is constant and the voltage increases
- Phase 2: The current decreases and the voltage is constant

When the recharging current falls below a certain value, the batteries are considered charged and the cycle is over. In this situation the output goes to the floating value which is the minimum value necessary for correct recharging maintenance battery.

WIRING

- Power cables AC and DC sections = FS17 CPR Cca-s3,d1,a3
- Signaling and control cables = FRO-HP CPR Cca-s3,d1,a3
- FLAT CABLE = Flame Classification FT1,FT2
- Data transmission cables = Cavo RJ45 - CAT5 FTP

ALARMS RELAY CARD

There is a board consisting of 7 alarm relays with SPDT type contact shown on removable and polarized printed circuit terminals. The electrical contacts have a range of 5Amp to 250Vac. There are three fixed alarms respectively:

- **AC MAINS PRESENCE** - wired in positive logic
- **GENERAL FAILURE** - wired in positive logic
- **LOW BATTERY VOLTAGE**

While it is possible to configure the remaining 4 from the HMI. From HMI you can configure 4 alarms depending on the menu on HMI.

INPUT TRANSFORMER

The power transformer is made with a core of first choice laminations (optional the solution with oriented crystals) and an electrostatic screen between primary and secondary. It produces the reduction of the input voltage to the most appropriate value for the operation of the conversion system and insulation from the network (4kV).

The transformer is made with class F supports and insulators (155 ° C) while the windings are in electrolytic copper class H double insulation (220 ° C). There is an electrostatic shield connected to earth between primary and secondary. The transformers comply with the Standard CEI EN 61558-2-4-file 4971 classification CEI 96-7.

BATTERY EFFICIENCY ANALYSIS “B.E.A.”

Advanced feature that determines the state of efficiency of the battery through the mathematical comparison between the real trend of the voltage during the discharge of the battery and the theoretical curve based on **Peukert's law**.

POWERBOOST FUNCTION

In case of RS overload, the RCB branch activates automatically connecting itself in parallel with the load and with the entire battery bank. The device automatically turns its configuration from **DOUBLE BRANCH** to **SINGLE BRANCH** with **TWO UNITS IN PARALLEL**, only for the overload status duration; in this condition, the output voltage of the entire system will be set to the "charge conservation" voltage value to allow also the battery bank simultaneous charging.

The function can be permanently activated by the user via the appropriate keys on **HMI** in the password-protected area. It is important to notice that both the branches must have the same power and the same characteristics. With this type of system, a configuration of **REDUNDANCY AND PARALLEL of POWER** is obtained in order to increase system reliability and to ensure a high degree of safety towards the load.

REVERSIBILITY OF OPERATION BETWEEN THE TWO BRANCHES

Titanium rectifier series includes two units of AC/DC conversion which work independently when input power is present. The converter "battery branch" charges the battery independently from the load; contemporarily the "system branch" will independently supply the load to a voltage threshold with tolerance $\pm 1\%$ from the voltage of charge the batteries.

In order to avoid the power interruption to the load in case of failure of the System Branch (RS) or the Battery Branch (RCB) the following solution is performed:

STANDARD OPERATION: during network operation, the two converters operate independently; The Battery Branch charges the battery with voltage dependent on the type of battery provided while the System Branch powers the load with stabilized nominal voltage $\pm 1\%$.

BLACKOUT OPERATION: In case of total loss of line or breakdown of both rectifiers, a sequence of operations in order to connect the load directly to the battery (without voltage drops) is activated.

RS FAILURE (System Branch): The System Branch failure activates the automatic and simultaneous switch on the branch battery, thus powering the load and simultaneously charging the battery in buffer. In this case, the voltage at the load is contained in the range $V_n + 10\%$ (adjustable).

RCB FAILURE (Battery Branch): in case of battery branch failure the branch battery, the switch to activate the service branch to power the loads and ensure battery charging with emergency voltage equal to $V_n + 10\%$ (adjustable) is automatically activated.

After failure recovery, the system automatically starts to operate again restoring the original function to each of the converters.

TITANIUM PLUS 2R-SCR

DC POWER SUPPLY SYSTEMS



APPLICATIONS

- Oil & Gas
- Energy production and distribution
- Process controls
- Transportation
- Safety
- Telecommunications
- Tertiary

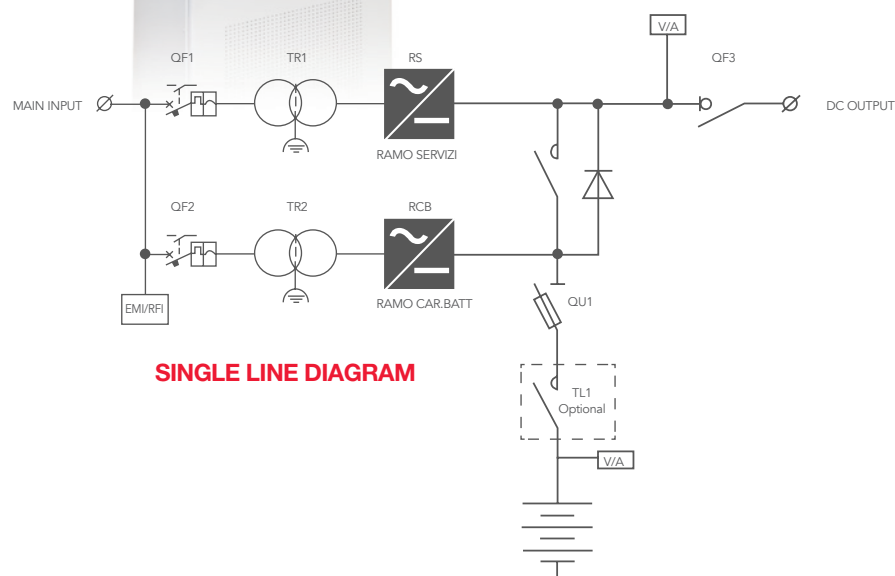

SINGLE LINE DIAGRAM

DOUBLE BRANCH Rectifier - SCR type

TITANIUM PLUS 2R-SCR is a Double Branch rectifier, provided with two independent SCR-based AC/DC conversion units, one powering the DC loads with stabilized voltage and the other one dedicated to charge the battery. The rectifier is assembled in an industrial cabinet 2000mm height and can be supplied with sealed or vented Lead Acid and NiCd batteries. The AC/DC conversion units are removable, in order to improve the efficiency and obtain an high MTBF with an extremely low MTTR. Further, the rectifier is provided with two input insulation transformers (one for each branch), in order to contain the output voltage ripple, and features our latest HMI, including a touchscreen display 7" with integrated web server and MODBUS TCP/IP communication protocol.

MAIN FEATURES

- Input insulation transformer at mains frequency, with an electrostatic shield
- SCR Power Bridge Rectifier **Total-controlled on REMOVABLE UNITS**
- Control type: High frequency PWM
- System control with industrial PLC on REMOVABLE UNITS
- Charge curve for each type of battery (AGM - GEL - PB - NICKD) 3 charging levels including manual charging complete with safety timer
- HMI - Digital control panel with touchscreen display 7" with integrated Web server
- High efficiency and reliability
- Easy maintenance with access from the front and removable power units
- Extended frequency range accepted as input
- Low residual ripple as output and on batteries (RIPPLE)
- Automatic and manual battery test (performing a true discharge battery test)
- **BEA** Function (Battery Efficiency Analysis)
- DC polarity on the ground sensor
- MODBUS TCP/IP communication (slave – server)
- Alarm cards with 3 fixed relays and 4 completely programmable by user
- Temperature compensation with PT100 sensor and correction coefficient (Vel/°C) settable by the user

STANDARD FUNCTIONS

- Automatic circuit breaker with cont. aux.

BATTERY CHARGE BRANCH - RCB

- Floating charge
- Boost charge
- Manual charge
- Emergency operating voltage
- Temperature compensation
- Test battery function
- **BEA** function (Battery Efficiency Analysis)

SERVICE BRANCH - RS

- Normal operating voltage
- Emergency operating voltage

SYSTEM

- Poweboost function
- Relay alarm card
- DC earth pole sensor



SIGNALS AND MEASURES

- AC Mains ON
- AC/DC RS ON
- AC/DC RCB ON
- RS Rectifier High voltage output
- RCB Rectifier High voltage output
- RS Rectifier Low voltage output
- RCB Rectifier Low voltage output
- RCB Floating charge
- RCB Boost charge (x)
- RCB Manual charge (x)
- Active temperature compensation (x)
- Battery charging current limitation ON
- Positive grounded pole
- Negative grounded pole
- Output overload
- Battery test in progress
- Battery test failed
- Operating from batteries
- Low battery voltage
- End of battery drain
- High battery temperature (x)
- AC input MCB OFF AC

(x) HMI - enable function

HMI PANEL

- Output voltage
- Output current
- Battery voltage
- Current battery charge
- Battery temperature

COMMUNICATION (Modbus slave TCP/IP)

Individual word for electrical parameters:

- Output voltage to loads
- Output current to loads
- Battery voltage
- Current battery charge
- Battery temperature

DoubleWord alarms:

- Showing all the signals present on the HMI

TITANIUM PLUS 2R-SCR

GENERAL	BATTERY	Suited for sealed (VRLA) or vented Lead Acid or NiCd battery			
	CHARGING CHARACTERISTICS	IU (according to DIN 41773) floating, boost and manual charging			
OUTPUT	NOMINAL VOLTAGE (V)	24	48	110	220
	CURRENT RANGE	60 ÷ 500 A			60 ÷ 250 A
	MAXIMUM POWER (W)	12000	24000	55000	55000
	RIPPLE NOISE (RMS)	1%			
	Vout SETTING RANGE	+/- 5%			
	VOLTAGE STABILITY	+/- 1%			
	Vin VARIATION SETTING	+/- 1%			
	LOAD VARIATION SETTING	+/- 1%			
	START-UP TIME	10 sec.			
	INPUT	VOLTAGE RANGE	three-phase 400Vac ±10%		
INPUT FREQUENCY		50 ÷ 60 +/-5%			
EFFICIENCY (Typ.)		≥ 90 %			
I70 INSULATION		4kV by transformer			
INPUT		Automatic circuit breaker			
BATTERY		Fuses			
OUTPUT		Switch			
OVERLOAD		<120% for 20 minuti, >150% for 5 secondi			
CURRENT CURVE		Constant			
OVERVOLTAGE		+ 10% Vn			
UNDERVOLTAGE	- 50% Vn				
PROTECTIONS	OVERTEMPERATURE	Shut down. Automatic restart after temperature reset			
	ALARMS	ALARM CARD WITH N.3 RELAYS SPDT 5A/250VAC	AC Mains presence, General Failure, Low Battery voltage		
AMBIENT	N. 4 USER PROGRAMMABLE RELAYS VIA HMI PANEL				
	OPERATING TEMPERATURE	-10+40°C			
	OPERATING HUMIDITY	< 95% without condensation			
	STORAGE TEMPERATURE	-20+70°C			
	NOISE LEVEL	according EN50091 < 60 dBA (typical value with forced ventilation in operation)			
STANDARDS	MARKING	CE			
	PROTECTION DEGREE	IEC 60529			
	EMC	EN 61000-6-2 EN 61000-6-4			
	STATIC CONVERTERS	EN 60146			
	DC-UPS (performance, routine test, requirements)	IEC 62040-5-3			
PROTECTION DEGREE (closed door)	IP31 standard, others on demand				
COLOR	RAL 7035 cabinet - RAL7012 roof and base				

* Relay normally operating in positive safety

The **SYSTEM CONTROL** is now based on an expandable Industrial PLC, characterized therefore by a very high reliability as well as by a considerable flexibility, it allows to satisfy a greater number of technical needs and consequent applications. This section, which constitutes the “intelligent” heart of our system, is now made in a special drawer located on the inside of the main door of the cabinet and **FULLY REMOVABLE** thanks to the presence of a polarized connector. This solution introduces a very important advantage, in fact it is possible to replace this assembly while hot, with the machine running, without turning off the system.

This is possible as the AC / DC conversion units recognize the loss of communication with the drawer and set themselves up in **AUTOMATIC SAFE MODE**, actually working independently and guaranteeing continuity of operation.

Once the drawer has been replaced and the connection re-established, the AC/DC units will return to operate under the automatic control of the PLC, resuming normal and complete operation. The HMI (Human Machine Interface) system has also been renewed, which now includes a touch panel, capacitive, 7 ”with excellent visibility characteristics, mechanical resistance to wear and connectivity with the outside world. Finally, a great deal of space was reserved for **REMOTE CONNECTION**, in fact now it is possible to control, parameterize and manage these systems in absolute safety through the **INTERNET** network thanks to the standard presence of the **WEB SERVER** function.

This has an undoubted advantage that significantly improves the maintenance and technical assistance aspects in critical installations.

DC POLARITY GROUNDED SENSOR

There is a fixed-threshold sensor (about 15mA, referring to the system’s output terminals) that detects possible loss of insulation of the output poles and batteries present in the system. This sensor is **NOT similar** to an **INSULATION CONTROL** instrument but is provided to give an initial indication of any abnormality.

The circuit detects the loss of insulation of the **POSITIVE** pole or the **NEGATIVE** pole differentiated. From HMI you can activate and deactivate the function.

AC/DC - THYRISTOR

It consists of a rectifier bridge in a fully controlled configuration.

FLOATING CHARGE

This recharge has two different phases:

- Phase 1: the current is constant and the voltage increases
- Phase 2: The current decreases and the voltage is constant

When the recharging current falls below a certain value, the batteries are considered charged and the cycle is over. In this situation the output goes to the floating value which is the minimum value necessary for correct recharging maintenance battery.

WIRING

- Power cables AC and DC sections = FS17 CPR Cca-s3,d1,a3
- Signaling and control cables = FRO-HP CPR Cca-s3,d1,a3
- FLAT CABLE = Flame Classification FT1,FT2
- Data transmission cables = Cavo RJ45 - CAT5 FTP

ALARMS RELAY CARD

There is a board consisting of 7 alarm relays with SPDT type contact shown on removable and polarized printed circuit terminals. The electrical contacts have a range of 5Amp to 250Vac. There are three fixed alarms respectively:

- **AC MAINS PRESENCE** - wired in positive logic
- **GENERAL FAILURE** - wired in positive logic
- **LOW BATTERY VOLTAGE**

While it is possible to configure the remaining 4 from the HMI. From HMI you can configure 4 alarms depending on the menu on HMI.

INPUT TRANSFORMER

The power transformer is made with a core of first choice laminations (optional the solution with oriented crystals) and an electrostatic screen between primary and secondary. It produces the reduction of the input voltage to the most appropriate value for the operation of the conversion system and insulation from the network (4kV).

The transformer is made with class F supports and insulators (155 ° C) while the windings are in electrolytic copper class H double insulation (220 ° C). There is an electrostatic shield connected to earth between primary and secondary. The transformers comply with the Standard CEI EN 61558-2-4-file 4971 classification CEI 96-7.

BATTERY EFFICIENCY ANALYSIS “B.E.A.”

Advanced feature that determines the state of efficiency of the battery through the mathematical comparison between the real trend of the voltage during the discharge of the battery and the theoretical curve based on **Peukert’s law**.

POWERBOOST FUNCTION

In case of RS overload, the RCB branch activates automatically connecting itself in parallel with the load and with the entire battery bank. The device automatically turns its configuration from **DOUBLE BRANCH** to **SINGLE BRANCH** with TWO UNITS IN PARALLEL, only for the overload status duration; in this condition, the output voltage of the entire system will be set to the "charge conservation" voltage value to allow also the battery bank simultaneous charging.

The function can be permanently activated by the user via the appropriate keys on **HMI** in the password-protected area. It is important to notice that both the branches must have the same power and the same characteristics.

With this type of system, a configuration of **REDUNDANCY AND PARALLEL of POWER** is obtained in order to increase system reliability and to ensure a high degree of safety towards the load.

REVERSIBILITY OF OPERATION BETWEEN THE TWO BRANCHES

Titanium rectifier series includes two units of AC/DC conversion which work independently when input power is present. The converter "battery branch" charges the battery independently from the load; contemporarily the "system branch" will independently supply the load to a voltage threshold with tolerance $\pm 1\%$ from the voltage of charge the batteries.

In order to avoid the power interruption to the load in case of failure of the System Branch (RS) or the Battery Branch (RCB) the following solution is performed:

STANDARD OPERATION: during network operation, the two converters operate independently; The Battery Branch charges the battery with voltage dependent on the type of battery provided while the System Branch powers the load with stabilized nominal voltage $\pm 1\%$.

BLACKOUT OPERATION: In case of total loss of line or breakdown of both rectifiers, a sequence of operations in order to connect the load directly to the battery (without voltage drops) is activated.

RS FAILURE (System Branch): The System Branch failure activates the automatic and simultaneous switch on the branch battery, thus powering the load and simultaneously charging the battery in buffer. In this case, the voltage at the load is contained in the range $V_n + 10\%$ (adjustable).

RCB FAILURE (Battery Branch): in case of battery branch failure the branch battery, the switch to activate the service branch to power the loads and ensure battery charging with emergency voltage equal to $V_n + 10\%$ (adjustable) is automatically activated.

After failure recovery, the system automatically starts to operate again restoring the original function to each of the converters.



HMI TITANIUM PLUS

DC POWER SUPPLY SYSTEMS

Each TITANIUM rectifier in 1R, 2R and 2RP configuration can be supplied in two versions: **PLUS**, which features the most advanced battery recharging and HMI (Human Machine Interface) technologies;

PLUS-E; specifically engineered for demanding but more cost-sensitive applications. Both versions are provided with a multilingual display, which is designed to be hot swappable, without therefore interrupting the system operation and causing plant downtime.

TITANIUM PLUS KEY FEATURES:

- **Three charge levels** (floating, boost and manual) available as standard, with temperature compensation system, which adapts the floating voltage according to the environment temperature of the battery
- Equipped with a **7" capacitive colour touch screen display**, with anti-reflection and scratch-resistant glass, with excellent mechanical resistance and visibility even in poorly lit environments
- From the HMI display it is possible to view a very wide range of **rectifier information**, widely configurable on the basis of the customer's needs: mimic diagram of the system, electrical input, output, battery measurements, auxiliary contacts of the switches, signals, alarms, battery temperature graph etc.
- Integrated **web-server** that enables remote assistance activity: the display can be controlled by remote and with any device (PC, smartphone, tablet...) the engineer can set the rectifier parameters and can view all the measurements, signals and alarms. If requested by the Client, the operation can also be performed directly by ZUTRONIC technical assistance
- **Email sending** function: in the event of anomalies and alarms, the rectifier sends automatic emails (up to n.3 recipients)
- **MODBUS@ TCP/IP** communication protocol available in slave configuration, for the connection of the rectifier to external centralized industrial control systems
- Equipped with **n.7 alarm relays** with SPDT type contact, n.3 fixed and n.4 that can be configured by the User through the display
- As standard, it integrates the **automatic and manual battery test**, which can be activated from the HMI display. During the test it is performed an effective battery discharge test, making possible to immediately detect anomalies in the battery circuit and to drastically reduce the sulphation phenomenon, keeping the batteries intact for their expected life.
- From the display it is possible to consult the technical product documents (manuals and wiring diagrams) in digital PDF format
- **Engineered product** which offer the maximum configurability according to the Client needs and Technical Specifications

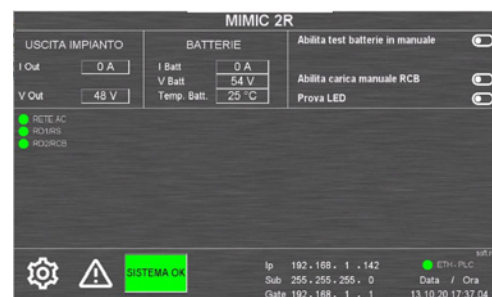

TITANIUM PLUS configuration 2R

Example of display reporting system in regular operation

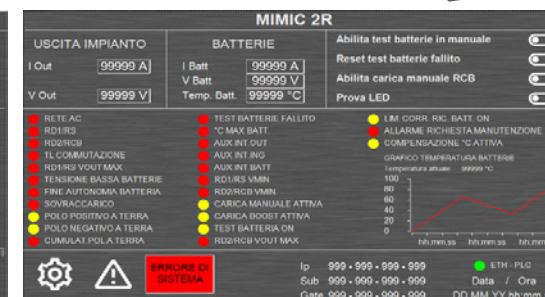

TITANIUM PLUS configuration 2R

Example of display reporting alarms and faults



TITANIUM PLUS

System navigation menu

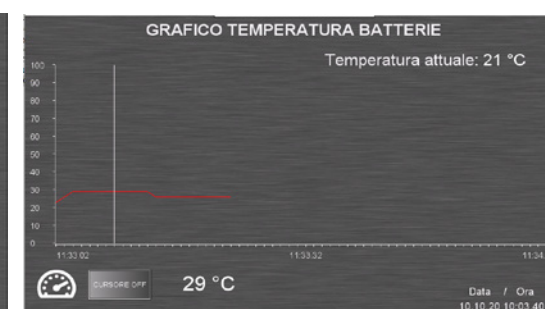

TITANIUM PLUS

Example of battery temperature graph

BEA "BATTERY EFFICIENCY ANALYSIS" FUNCTION

Latest development by ZUTRONIC R&D, the Battery Efficiency Analysis "BEA" is an advanced function that determines the state of efficiency of the battery through the mathematical comparison between the real trend of the battery discharging voltage and the theoretical curve based on Peukert's Law.

By comparing these curves it is possible to verify the state of efficiency of the battery: if the real trend is lower than the theoretical curve, the battery is in a non-optimal condition.

In the case of battery discharge, the system will automatically start to track the discharge curve, showing the trend directly on the rectifier HMI display and it is also displayed the theoretical back-up time.

Furthermore, the last 5 performed tests can be downloaded via USB stick, allowing the user to carry out analyses on a PC in order to monitor the battery ageing.



Battery Efficiency Analysis "BEA" Function

HMI TITANIUM PLUS-E

DC POWER SUPPLY SYSTEMS

TITANIUM PLUS-E KEY FEATURES:

- Developed to recharge batteries with floating voltage, as option available boost and manual charge mode
- Equipped with a 7" **resistive color display**, suited for operating in industrial environments, showing the system mimic and the main measures, signals and alarms
- Provided as standard with MODBUS® RTU communication protocol on RS485 port, in slave configuration, for the connection of the rectifier to external centralized industrial control systems
- Equipped with **n.3 fixed alarm relays** with SPDT type contact ("Mains presence", "General failure", "Low battery voltage")
- Earth pole sensor provided as standard, to detects possible insulation losses on the output poles and on the batteries, discriminating positive and negative pole
- Designed for technical demanding and also price-sensitive applications

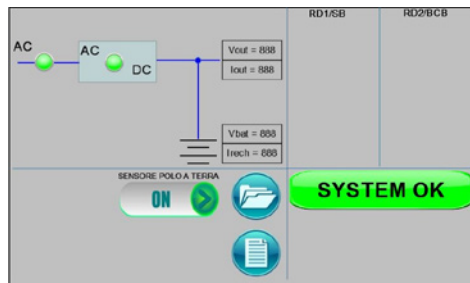

TITANIUM PLUS-E configuration 1R

Example of display reporting system in regular operation

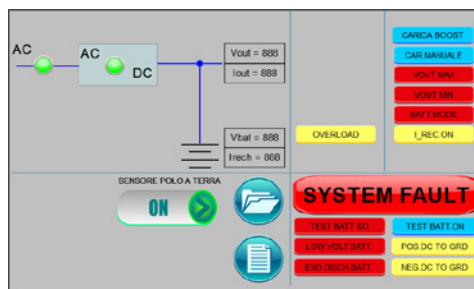

TITANIUM PLUS-E configuration 1R

Example of display reporting alarms and faults

TITANIUM PLUS / PLUS-E VERSION COMPARISON

CARATTERISTICA	PLUS	PLUS-E
Configuration 1R/2R/2RP	✓ As standard	✓ As standard
Floating charge	✓ As standard	✓ As standard
Boost charge	✓ As standard	□ Optional
Manual charge	✓ As standard	□ Optional
Voltage compensation according to battery temperature	✓ As standard	N.A.
Touch screen HMI 7" display	Capacitive	Resistive
System mimic	✓ As standard	✓ As standard
Measurement and display of output voltage and current	✓ As standard	✓ As standard
Measurement and display of battery voltage and current	✓ As standard	✓ As standard
Measurement and display of AC input voltage and current	□ Optional	N.A.
Visualization on the display of the auxiliary contacts of the input/output/battery breaker	✓ As standard	N.A.
Integrated Web-server	✓ As standard	N.A.
Display remotization with ZUTRONIC teleassistance (if required)	✓ As standard	N.A.
Automatic e-mail sending	✓ As standard	N.A.
MODBUS® communication protocol	As standard TCP/IP, optional RTU	As standard RTU
SNMP, IEC61850, PROFINET communication protocols	□ Optional	N.A.
SPDT alarm relays	3 fixed and 4 configurable	As standard 3 fixed
Automatic and manual battery test	✓ As standard	Optional
Function "Battery Efficiency Analysis - BEA"	✓ As standard	N.A.
Technical documents displayed through the display	✓ As standard	N.A.
"Powerboost" function (only for 2R configuration)	✓ As standard	✓ As standard
Branch function change (only for 2R configuration)	✓ As standard	✓ As standard
DC polarity on the grounded sensor	✓ As standard	✓ As standard
Alarms and events log	✓ As standard	✓ As standard
Supported languages	All	English, Italian, French
Firmware update through USB pendrive	✓ As standard	N.A.

SINE and MICRON

INVERTER

DC/AC INVERTER WITH 1PH OUTPUT

SINE series are industrial DC/AC inverters, available with **24Vdc**, **48Vdc** and **110Vdc** input voltages and with a power range from **650W** to **6300W**.

These products are designed to respond to the most critical requests, thanks to the high level of reliability, very robust mechanics and the galvanic isolation.



TOWER VERSION

Output power from **650W** to **6300W**

Input voltage:

24Vdc 48Vdc 110Vdc+



VERSION FOR WALL MOUNTING

Output power from **650W** to **6300W**

Version for wall mounting, designed to save space on the ground



MICRON VERSION

Output power from **100W** and **300W**

Compact industrial version, with high safety in very small dimensions



VERSION FOR RACK MOUNTING

Output power from **650W** to **6300W**

Industrial version for integration in industrial cabinet

WIDE VOLTAGE INPUT RANGE

Very wide range of input voltage, allowing to install the inverter in every conditions:

24Vdc: from **19Vdc** to **43Vdc**

48Vdc: from **39Vdc** to **80Vdc**

110Vdc: from **88** to **145Vdc**

GALVANIC INSULATION

Provided as standard with toroidal output transformer which guarantees 4000V of galvanic isolation and the total load protection.

LOW VOLTAGE ELECTRONICS

Key feature that allows to safeguard the personnel involved during the operation of the unit: no high voltage is present inside the electronic section.

APPLICATIONS

- Telecommunication
- Transportations
- Naval
- Industry
- Airports

The **SINE** series can be adopted to convert the DC input voltage into 1Ph AC output voltage with a perfect sine wave, suited for powering sensitive loads.

A wide input voltage range allows to accept many DC voltages, even if not stabilized, without installing a DC/DC converter:

24Vdc: from **19Vdc** to **43Vdc**

48Vdc: from **39Vdc** to **80Vdc**

110Vdc: from **88** to **145Vdc**

The presence of the toroidal transformer on the output with 4000V of galvanic isolation guarantees high protection and safety for the connected load.

SINE models are also the right answer for moving systems thanks to their mechanical robustness and the possibility of applying specific anti-vibration treatments. In addition to the standard **TOWER**, **RACK** and **WALL** versions, it is possible to have products with special layouts according to the different needs of the Client, thanks to a specialized staff of mechanical engineers.

The **MICRON** series has been designed following the same characteristics and the same level of safety and reliability of the **SINE** series. In short, they are a small and compact industrial inverters available in 2U Rack version with 48Vdc or 110Vdc input voltages and 250W and 600W output power. They are the perfect solution for the telecommunications sector and for the critical industrial environments.

GENERAL DATA – SINE 24V

MODEL	DATA	SINE 24-3	SINE 24-4	SINE 24-5	SINE 24-6	SINE 24-7	SINE 24-8
POWER	OUTPUT POWER	525W	900W	1100W	1350W	1600W	1850W
	OUTPUT STARTING SURGE	1000W	1600W	2000W	2200W	2600W	3000W
TECHNOLOGY	INVERTER	PWM Microprocessor					
SIGNALS	OPTIC / ACOUSTIC	Mains present, DC present, low DC, critical temperature, overtemperature, overload/short circuit, by-pass operation					
	REMOTE CONTACTS	DB9 standard card: DC present, low DC Optional multi-contacts DB9 card: on/off, DC present, DC low, critical temperature, inverter fault, overload/short circuit, by-pass operation					
AMBIENT	OPERATING TEMPERATURE	0°C a +45°C / Stock: -10°C a +60°C					
	NOISE LEVEL	<28dB	<30dB			<42dB	
MECHANICAL DETAILS	PROTECTION DEGREE / COLOR	IP20 / RAL 9006					
	TOWER /RACK	155x383x316h/3U	243x585x482h / 4U (443+53mm)			355x782+53x378h / 5U (443+53mm)	
	WEIGHT / KG.	20	33	36	41	46	53

INPUT / OUTPUT DATA – SINE 24V

MODEL	DATA	SINE 24-3	SINE 24-4	SINE 24-5	SINE 24-6	SINE 24-7	SINE 24-8
INPUT	VOLTAGE RANGE	19Vdc – 43Vdc					
	CONNECTION	Terminal block with automatic or fuses					
OUTPUT	VOLTAGE	230Vac single-phase					
	FREQUENCY	50Hz +/-0,01%					
	WAVE SHAPE	Pure sine wave generated by the microprocessor					
	INSULATION	4000V of galvanic isolation through a toroidal transformer					
	CONNECTION	Terminal block					
	ELECTRONIC PROTECTION	Overload – Short circuit					
	DISTORTION	<5% linear / <8% Not linear					
	VOLTAGE VARIATION	<1% Static / +/-3% Dynamic					
BY-PASS	EMERGENCY BY-PASS	Optional - upon request					
DISPLAY	LCD DISPLAY	Optional - upon request					

GENERAL DATA – SINE 48V

MODEL	DATA	SINE 48-3	SINE 48-4	SINE 48-5	SINE 48-6	SINE 48-7	SINE 48-9	SINE 48-11	SINE 48-15	SINE 48-18	SINE 48-22	SINE 48-27		
POWER	CURRENT/OUTPUT POWER	3A/650W	4A / 900W	5A/1100W	6A/1350W	7A/1700W	9A/2100W	11A/2500W	15A/3375W	18A/4050W	22A/4950W	27A/6300W		
	OUTPUT STARTING SURGE	1000W	1400W	1800W	2200W	3000W	3200W	3500W	5000W	6000W	6800W	7500W		
TECHNOLOGY	INVERTER	PWM Microprocessor												
SIGNALS	OPTIC / ACOUSTIC	Mains present, DC present, DC low, critical temperature, overtemperature, overload/short circuit, by-pass operation												
	REMOTE CONTACTS	Standard DB9 card: DCpresent, DC low Options on request: DB9 Multi-contacts card: on/off, DCpresent, DC low, critical temperature, inverter failure, overload/short circuit, by-pass function												
AMBIENT	OPERATING TEMPERATURE	0°C to +45°C / Stock: -10°C to +60°C												
	NOISE LEVEL	<28dB	<30dB				<42dB				30dB a 47dB			
MECHANICAL DETAILS	PROTECTION DEGREE / COLOR	IP20 / RAL 9006												
	TOWER /RACK	155 x 383 x 316h/3U	243x585x482h / 4U (443+53mm)				243x585x482h / 4U (443+53mm)				355x782+53x378h / 5U (643+53mm))			
	WEIGHT / KG.	21	32	34	37	42	47	54	62	68	74	80		

INPUT / OUTPUT DATA – SINE 48V

MODEL	DATA	SINE 48-3	SINE 48-4	SINE 48-5	SINE 48-6	SINE 48-7	SINE 48-9	SINE 48-11	SINE 48-15	SINE 48-18	SINE 48-22	SINE 48-27
INPUT	VOLTAGE RANGE	39/60Vdc	39/80Vdc									
	CONNECTION	Terminal block with automatic or fuses										
OUTPUT	VOLTAGE	230Vac single-phase										
	FREQUENCY	50Hz +/-0,01%										
	WAVE SHAPE	Pure sine wave generated by the microprocessor										
	INSULATION	4000V of galvanic isolation through a toroidal transformer										
	CONNECTION	Terminal block										
	ELECTRONIC PROTECTIONS	Overload – Short circuit										
	DISTORTION	<5% linear / <8% Not linear										
VOLTAGE VARIATION	<1% Static / +/-3% Dynamic											
BY-PASS	EMERGENCY BY-PASS	Optional - upon request										
DISPLAY	LCD DISPLAY	Optional - upon request										

GENERAL DATA – SINE 110V

MODEL	DATA	SINE 110-3	SINE 110-4	SINE 110-5	SINE 110-6	SINE 110-7	SINE 110-9	SINE 110-11	SINE 110-12	SINE 110-15	SINE 110-18	SINE 110-22	SINE 110-27		
POWER	CURRENT/OUTPUT POWER	3A/650W	4A / 900W	5A/1100W	6A/1350W	7A/1700W	9A/2100W	11A/2500W	12A/3000W	15A/3375W	18A/4050W	22A/4950W	27A/6300W		
	OUTPUT STARTING SURGE	1000W	1400W	1800W	2200W	3000W	3200W	3500W	4000W	5000W	6000W	6800W	7500W		
TECHNOLOGY	INVERTER	PWM Microprocessor													
SIGNALS	OPTIC / ACOUSTIC	Rete presente, DCpresent, DC low, critical temperature, overtemperature, overload/short circuit, by-pass function													
	REMOTE CONTACTS	Standard DB9 card: DCpresent, DC low Options on request: Multi-contacts DB9 card: on/off, DCpresent, DC low, critical temperature, inverter failure, overload/short circuit, by-pass function													
AMBIENT	OPERATING TEMPERATURE	0°C to +45°C / Stock: -10°C to +60°C													
	NOISE LEVEL	<28dB	<30dB				<42dB					30dB a 47dB			
MECHANICAL DETAILS	PROTECTION DEGREE / COLOR	IP20 / RAL 9006													
	TOWER /RACK	155 x 383 x 316h/3U	243x585x482h / 4U (443+53mm)				243x585x482h / 5U (443+53mm)				355x782+53x378h / 5U (643+53mm))				
	WEIGHT / KG.	19	30	32	35	40	45	50	55	62	66	72	78		

INPUT / OUTPUT DATA – SINE 110V

MODEL	DATA	SINE 110-3	SINE 110-4	SINE 110-5	SINE 110-6	SINE 110-7	SINE 110-9	SINE 110-11	SINE 110-12	SINE 110-15	SINE 110-18	SINE 110-22	SINE 110-27
INPUT	VOLTAGE RANGE	88-145Vdc											
	CONNECTION	Terminal block with automatic or fuses											
OUTPUT	VOLTAGE	230Vac single-phase											
	FREQUENCY	50Hz +/-0,01%											
	WAVE SHAPE	Pure sine wave generated by the microprocessor											
	INSULATION	4000V of galvanic isolation through a toroidal transformer											
	CONNECTION	Terminal block											
	ELECTRONIC PROTECTIONS	Overload – Short circuit											
	DISTORTION	<5% linear / <8% Not linear											
BY-PASS	VOLTAGE VARIATION	<1% Static / +/-3% Dynamic											
	EMERGENCY BY-PASS	Optional - upon request											
DISPLAY	LCD DISPLAY	Optional - upon request											

GENERAL DATA – MICRON 48V and 110V

MODEL	DATA	MICRON 48-04	MICRON 48-1	MICRON 110-04	MICRON 110-1
POWER	CURRENT/OUTPUT POWER	0,43A / 100W	1,3A / 300W	1,3A / 300W	1,3A / 300W
	OUTPUT STARTING SURGE	250W	600W	250W	600W
TECHNOLOGY	INVERTER	PWM Microprocessor			
SIGNALS	OPTIC / ACOUSTIC	DCpresent, DC low, critical temperature, overtemperature, overload/short circuit			
	REMOTE CONTACTS	Standard DB9 card: DCpresent, DC low Options on request: Multi-contacts card on terminali: on/off, critical temperature, overtemperature, overload/short circuit			
AMBIENT	OPERATING TEMPERATURE	0°C a +45°C / Stock: -10°C a +60°C			
	NOISE LEVEL	<28dB			
MECHANICAL DETAILS	PROTECTION DEGREE / COLOR	IP20 / RAL 9006			
	TOWER /RACK	440x210x90h – 2U 480x210x90h			
	WEIGHT / KG.	7	9	7	9

INPUT / OUTPUT DATA – MICRON 48V and 110V

MODEL	DATA	MICRON 48-04	MICRON 48-1	MICRON 110-04	MICRON 110-1
INPUT	VOLTAGE RANGE	39/70Vdc		89/145Vdc	
	CONNECTION	Connector			
OUTPUT	VOLTAGE	230Vac single-phase			
	FREQUENCY	50Hz +/-0,01%			
	WAVE SHAPE	Pure sine wave generated by the microprocessor			
	INSULATION	4000V of galvanic isolation through a toroidal transformer			
	CONNECTION	Nr. 2 outputs on connectors - nr. 1 Schuko socket			
	ELECTRONIC PROTECTIONS	Overload – Short circuit			
	DISTORTION	<5% linear / <8% Not linear			
	VOLTAGE VARIATION	<1% Static / +/-3% Dynamic			
DISPLAY	LCD DISPLAY	Optional - upon request			

IRON

INVERTER



SINGLE-LINE DIAGRAM

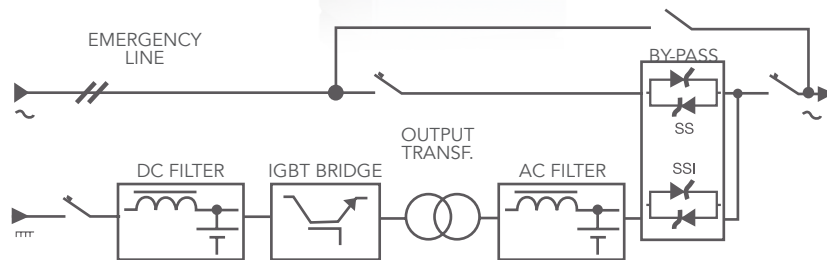

DC/AC SINGLE PHASE OR THREE PHASE OUTPUT

Iron series are Industrial, Heavy Duty Inverters designed to supply critical AC Loads with stabilised continuous voltage. Products can be easily customized depending on the peculiar Customer request.

Transformer for AC/DC galvanic separation are included Microprocessor control and Digital control panels

APPLICATIONS

- Oil & Gas
- Petrochemical
- Power & Utilities
- Industry
- Hydroelectric and Geothermal plant

MAIN FEATURES

- Industrial Layout
- Static Conversion
- Microprocessor control
- Digital control panel
- Reduced output THD with not linear load - IGBT technology bridge (PWM)
- Natural convection cooling
- Easy maintenance/front access
- Insulation: input/output galvanic insulation

MAIN OPTIONS

- Static and manual Switch
- Bypass Transformers and Voltage Regulators
- AC Distribution Panels
- Redundant ventilation
- Communication Port: USB or RS485 or Ethernet TCP/IP with Modbus protocol
- Tropicalization

IRON-M (Single-phase) and IRON-T (Three-phase)

OUTPUT	VOLTAGE	Single-phase 230 Vac or three-phase 400Vac (Others on demand)	
	FREQUENCY	50 + 60 Hz	
	NOMINAL POWER	single-phase max 25KVA (Vbattery=110Vcc) single-phase max 50KVA (Vbattery=220Vcc) three-phase max 45KVA (Vbattery=110Vcc) three-phase max 90KVA (Vbattery=220Vcc)	
	STATIC REGULATION	±1%	
	DYNAMIC REGULATION	<5% with recovery to 2% in 40 ms	
	ARMONIC DISTORTION	≤ 3% with carico linear / ≤ 5% with carico non linear CF 3:1	
	OVERLOAD	110% Pn for 2h - 125% for 10 min - 150% for 10 sec	
	PROTECTIONS	Overvoltage, Overload	
	INPUT	NOMINAL VOLTAGE (V)	110, 220 Vcc (other on demand)
		RANGE (VOLTAGE)	-20% +40%
BY-PASS EMERGENCY LINE INPUT VOLTAGE		single-phase 230Vac ±10% or three-phase 400Vac ±10% (other on demand)	
INRUSH CURRENT		<8 In	
PROTECTIONS		Overvoltage, Undervoltage	
GENERAL	COOLING SYSTEM	Natural convection cooling (depending on the powers)	
	OPERATING TEMPERATURE	-10°C + 50°C	
	RELATIVE HUMIDITY	≤ 95% a 40°C	
	ALTITUDE	≤ 1000 m	
	ACOUSTIC NOISE	≤ 60dba a 1 meter	
	EFFICIENCY AT FULL LOAD	≥ 88%	
	MTBF	140.000 hr A 30 °C	
STANDARDS	MARKING	CE	
	PROTECTION DEGREE	IEC 60529	
	EMC	EN 61000-6-2 EN 61000-6-4	
	SAFETY	IEC EN 50178	
	STATIC CONVERTERS	EN 60146	
PROTECTION DEGREE	IP20 (other on demand)		
COLOR	RAL 7035 (other on demand)		



WAVE

AC POWER SUPPLY SYSTEMS

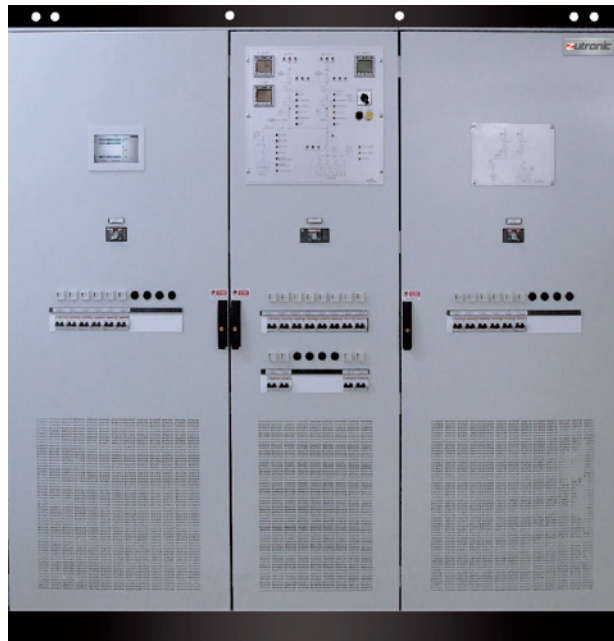

AC/AC SINGLE PHASE OR THREE PHASE OUTPUT UPS

WAVE is an industrial double conversion ON-LINE UPS, designed to guarantee a continuous and stabilized power supply to critical loads. WAVE is developed as a "Heavy Duty" equipment thanks to its reliability, and it is particularly suited to harsh environmental conditions. The product can be easily customized according to the Client's needs and can be configured on the basis of the project's Technical Specifications. Transformer for AC/DC galvanic isolation, static and manual bypass are provided as standard, as well as microprocessor control and digital HMI interface.

The product can be combined with sealed or vented lead acid or NiCd batteries.

MAIN FEATURES

- Industrial layout, custom made
- Very high level of customizability
- ON LINE double conversion configuration
- Microprocessor controlled
- HMI LCD digital display
- THD di uscita ridotto con carichi lineari
- Reduced output THD with not linear load
- Inverter unit IGBT-based (PWM)
- Battery voltage Temperature compensation
- Easy maintenance with front access
- IN/OUT galvanic insulation

OPTIONS

- Rectifier bridge thyristor 12-pulse
- Bypass line isolating transformer
- Bypass line automatic voltage regulator AVR
- AC & DC distribution boards
- Redundant ventilation
- Dual redundant parallel configuration
- Communication interfaces (Modbus 485 - TCP/IP - Ethernet)
- Printed circuit boards tropicalization
- Heater resistor
- MCCB/ mothorized MCCB breakers
- Customized IP protection degree (e.g. IP31, IP42...)
- Fuse box / Breaker box for battery protection

EXAMPLES OF WAVE CONFIGURATIONS (SINGLE LINE DIAGRAM)

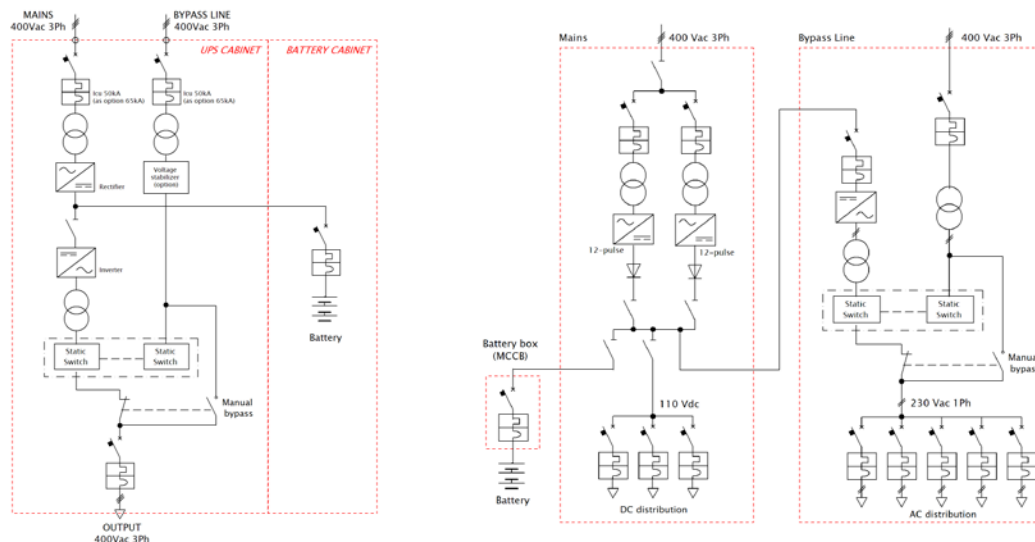

Single WAVE industrial UPS, with bypass line and batteries in dedicated cabinet

APPLICATIONS

- Oil & Gas
- Petrochemical
- Power & Utilities
- Industry
- Impianti Idroelettrici and Geotermici

Redundant WAVE industrial UPS with thyristor 12-pulse rectifier bridge, dedicated cabinet for inverter unit and bypass line, DC and AC distribution boards and battery racks

WAVE-TM (Single-phase) and WAVE-TT (Three-phase)

OUTPUT	NOMINAL VOLTAGE (V)	1Ph 230 Vac / 3Ph 400Vac 50/60 Hz (other upon request)
	BY-PASS EMERGENCY LINE INPUT VOLTAGE	1Ph 230Vac ±10% or 3Ph 400Vac ±10% (other upon request)
	NOMINAL POWER (COSPHI=0,8)	1Ph: max 50KVA (VBatteries=110Vdc), max 100KVA (VBatteries=220Vcc) 3Ph: max 100KVA (VBatteries=110Vdc), max 150KVA (VBatteries=220Vcc)
	STATIC STABILITY	±1%
	DYNAMIC STABILITY	± 5% (load step) with recovery 2% in 40 ms
	ARMONIC DISTORTION /THD)	≤ 2% with linear load / ≤ 5% with not linear load CF 3:1
	OVERLOAD	105% continuous - 125% for 10 min - 150% for 1 min. 200% for 100 ms
PROTECTIONS		Overvoltage, undervoltage
INPUT	NOMINAL VOLTAGE (V)	3F 400Vac 50/60Hz (other upon request)
	POWER FACTOR	0,8 at full load
	THD	≤ 30% (rectifier bridge 6-pulse), ≤ 12% (rectifier bridge 12-pulse)
BUS DC	VOLTAGE BUS DC	110Vdc / 220Vdc / 400Vdc
CONTROL and SIGNALS	MICROPROCESSOR	High performance 8-Bit digital microcontroller
	LCD DISPLAY	Backlit graphic LCD display for measurements, alarms and status messages
	MIMIC PANEL	UPS with 9 LED graphic block diagram
	LED SIGNALS	Inverter ok, Inverter faulty, Rectifier Ok, Rectifier faulty
	VOLT FREE SIGNALLING CONTACTS	Power failure Input, Faulty rectifier, Low/High DC voltage, Battery discharging, Battery disconnected, Faulty inverter, Inverter overload, Inverter overtemperature, Low/High AC output voltage, Fan fault, Grounded pole (option).
GENERAL	COOLING SYSTEM	Cabinet: Natural - Semiconductor - Heat sink: Fan assisted
	OPERATING TEMPERATURE	0°C + 40°C without condensation
	HUMIDITY	≤ 95% a 40°C
	ALTITUDE	≤ 1000 m without derating
	NOISE	≤ 65-70dba a 1 meter
	EFFICIENCY AT FULL LOAD	≥ 88%
	MTBF	140.000 hr aTt 30 °C
	PROTECTION DEGREE	IP30 (other options available upon request)
	COLOR	RAL 7035 (other options available upon request)
	ACCESS	Front door
STANDARDS	MARKING	CE
	PROTECTION DEGREE	IEC 60529
	EMC	EN 61000-6-2, EN 61000-6-4, IEC 62040-2
	SAFETY	IEC EN 50178, IEC 62040-1
	SEMICONDUCTOR CONVERTERS	EN 60146
	AC UPS (performance)	IEC 62040-3

Battery Monitoring Unit

ACCESSORIES

The continuous growing demand for systems that guarantee a higher service continuity, powered by direct current, is leading to the development of monitoring equipment to make the system even more reliable, avoiding unexpected and sudden failures.

The DC power source composed by the batteries is the most vulnerable point of the system: therefore, a monitoring unit has been developed to check the operating status of the battery bank and the single battery cell (or element).

This unit consists of a modular support card for the physical connection with the single battery, while the display of the parameters, the alarms management and the remote communication is provided by the HMI display of the TITANIUM PLUS HMI rectifier.

The purpose of the monitoring system is the prevention of malfunctions and the possibility to schedule maintenance interventions in advance, avoiding sudden breakdowns with consequent loss of service

MAIN FEATURES

- Checking and monitoring the operating parameters
- Reporting any anomalies
- Helps to keep the battery efficient
- Allows the engineer to check the battery status in complete safety from remote

TECHNICAL FEATURES

- Power supply: mains or batteries by adopting a special adapter
- Operating temperature: from -20°C to +50°C
- Number of channels for acquiring battery voltages: 10
- Voltage range for each channel: 0 ÷ 60Vdc
- Measurable temperature range: from -40°C to +80°C
- Communication interface: Modbus 485 RTU

VISUALIZATION (through TITANIUM PLUS HMI display)

- Battery total voltage
- Voltage of each single channel
- Charge and discharge current (if current sensor is provided)
- Alarms
- Date and time measurement
- Environment and battery temperature (if PT100 probe is provided)

AS OPTION

- Current sensor
- PT100 temperature probe

BATTERIES

ACCESSORIES

Over the years, Zutronic has strengthened a solid cooperation with the main international battery manufacturers.

We may also provide technical support for the correct battery choice and sizing (even with IEEE software) about all the current technologies:

- **VRLA** (Valve Regulated Lead-Acid); commonly know as hermetic Lead-acid Batteries, they are available both in GEL or AGM (Absorbent Glass Mat).
- **VENTED**; commonly know as open Lead-acid Batteries (Flooded), they are the traditional batteries in an open transparent shell, usually available in single 2V cell and normally installed in dedicated room
- **NI-CD**; Nichel-cadmium batteries with high performances and very long life for critical applications.
- **LITHIUM**; The most recent technology, particularly suited for storage and cyclic use.
- **SODIO CLORURO DI NICHEL**; commonly "salt battery", offer excellent performance, long expected life and total recyclability

Depending on the technology and applications, we can supply metal racks for batteries installation, or steel battery cabinets complete of electrical protections and monitoring systems.





Technologic devices require a special attention during the start up activity and along their operating life in the site. This is the reason why ZUTRONIC, directly or through local partners, may offer several dedicated services:

SYSTEM START-UP

This activity is performed by a specialized technician following a precise procedure included in the Company Quality System, verifying all the working conditions, site and equipment as well.

In short, the system start up consists in:

- Verification that all the site installation conditions comply
- Visual verification of all the devices and batteries to identify possible damages
- Verification that the devices are correctly connected to the system
- Verification that the batteries are correctly connected
- Verification that all security legislation have been fulfilled
- Verification that all security devices (upstream and downstream the machine) have been correctly placed
- Verification of the power supply system
- First start of the machine and check of all working parameters
- Test with a real load
- Simulation of power blackout and return
- Eventual test of communication devices

The advantages of a Putting into service assisted by our technician are:

- Certainty of the proper working of the machine
- Training of the employees that will have in charge the leading of the site
- Longer life of the system
- Customization of the working parameters due to the real needs of the system
- Possibility to extend the warranty



AFTER SALE ASSISTANCE

Zutronic can offer several level of assistance based on the needs of the final customer and of the system itself. Our contracts offer an efficient protection for all installations type. Maintenances activities are performed by our specialized technicians or by authorized company of the territory.

Below the services offered:

- Maintenance agreement (with several level of assistance, that can be also multi-annual), for UPS and Rectifiers battery charger
- Warranty extention connected to the maintenance agreement
- Planned test of batteries charge (capacity and efficiency test)
- Training to the employees that will have in charge the leading of the system
- Old batteries substitution and their disposal
- Phone assistance (or directly to the site) by our specialized technician
- Plant survey

The advantages of a maintenance agreement are:

- Reduction of loss of production and system stop costs
- Guaranteed response time
- Technical report for each intervention
- Historical report of all the activities at the site
- Only original spare parts use
- Certified tools use
- Site assistance by specialized and authorized technicians

BATTERY REPLACEMENT

Batteries replacement requires a specific knowledge to guarantee the system efficiency and to prevent serious damages due to a wrong connection.

Setting the wrong polarity can cause an irreversible damage to the power continuity system.

Zutronic engineers can replace all types of batteries, ensuring the correct return of the service and a correct assistance to old batteries disposal.



zutronic[®]

Via Gaetano Donizetti, 109/111 - 24030 Brembate Di Sopra (BG)

Geller Business Centre - D2 Building

Tel. 035 4379962 Fax 035 592935

sales@zutronic.it

ISO9001:2015

BUREAU VERITAS
Certification



www.zutronic.it

[LinkedIn](#)