

TITANIUM PLUS 1R-SCR

DC POWER SUPPLY SYSTEMS

SINGLE BRANCH Rectifier - SCR type

TITANIUM PLUS 1R-SCR is a Single Branch rectifier, provided with a single SCR thyristor-based AC/DC conversion unit which supplies the loads and simultaneously charges the battery. The rectifier is assembled in an industrial cabinet 2000mm height and can be supplied with sealed or vented Lead Acid and NiCd batteries. The AC/DC conversion unit is removable, in order to improve the efficiency and obtain an high MTBF with an extremely low MTTR.

Further, the rectifier is provided with an input insulation transformer, in order to contain the output voltage ripple, and features our latest HMI, including a touchscreen display 7" with integrated web server and MODBUS TCP/IP communication protocol.



MAIN FEATURES

- Input insulation transformer at mains frequency, with an electrostatic shield
- Bridge rectifier Chopper on REMOVABLE UNITS
- Control type: High frequency PWM
- System control with industrial PLC on REMOVABLE UNITS
- Charge curve for each type of battery (AGM - GEL - PB - NI-CD)
- 3 charging levels including manual charging complete with safety timer
- HMI - Digital control panel with touchscreen display 7" with integrated Web server
- High efficiency and reliability
- Easy maintenance with access from the front and removable power units
- Extended frequency range accepted as input
- Low residual ripple as output and on batteries (RIPPLE)
- Low residual ripple as output and on batteries (RIPPLE)
- BEA Function (Battery Efficiency Analysis)
- DC polarity on the ground sensor
- MODBUS TCP/IP communication (slave – server)
- Alarm cards with 3 fixed relays and 4 completely programmable by user
- Temperature compensation with PT100 sensor and correction coefficient (Vel/°C) settable by the user

SINGLE LINE DIAGRAM

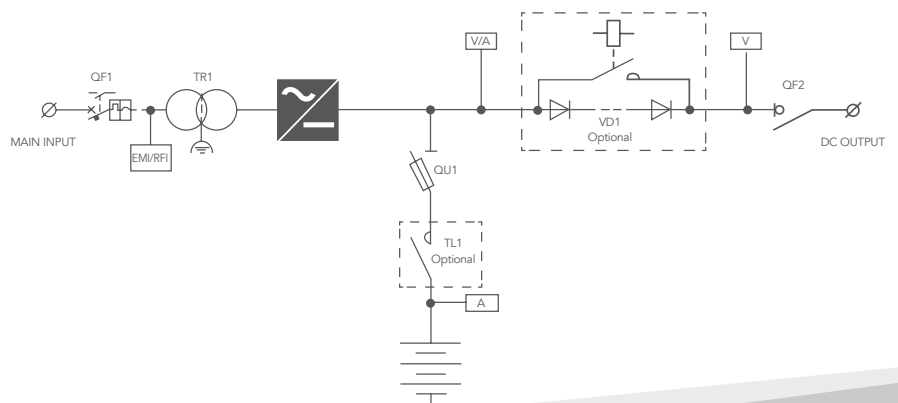

The **SYSTEM CONTROL** is now based on an expandable Industrial PLC, characterized therefore by a very high reliability as well as by a considerable flexibility, it allows to satisfy a greater number of technical needs and consequent applications. This section, which constitutes the “intelligent” heart of our system, is now made in a special drawer located on the inside of the main door of the cabinet and **FULLY REMOVABLE** thanks to the presence of a polarized connector. This solution introduces a very important advantage, in fact it is possible to replace this assembly while hot, with the machine running, without turning off the system. This is possible as the AC / DC conversion units recognize the loss of communication with the drawer and set themselves up in **AUTOMATIC SAFE MODE**, actually working independently and guaranteeing continuity of operation.

Once the drawer has been replaced and the connection re-established, the AC/DC units will return to operate under the automatic control of the PLC, resuming normal and complete operation. The HMI (Human Machine Interface) system has also been renewed, which now includes a touch panel, capacitive, 7 "with excellent visibility characteristics, mechanical resistance to wear and connectivity with the outside world. Finally, a great deal of space was reserved for **REMOTE CONNECTION**, in fact now it is possible to control, parameterize and manage these systems in absolute safety through the **INTERNET** network thanks to the standard presence of the **WEB SERVER** function. This has an undoubted advantage that significantly improves the maintenance and technical assistance aspects in critical installations.



SIGNALS AND MEASURES

- AC Mains ON
- AC/DC ON
- Rectifier High voltage output
- Rectifier Low voltage output
- Floating charge
- Boost charge (x)
- Manual charge (x)
- Active temperature compensation (x)
- Battery charging current limitation ON
- Negative grounded pole
- Output overload
- Battery test in progress
- Battery test failed
- Operating from batteries
- Low battery voltage
- End of battery drain
- High battery temperature (x)
- AC input MCB OFF AC

(x) HMI - enable function

APPLICATIONS

- Oil & Gas
- Energy production and distribution
- Process controls
- Transportation
- Safety
- Telecommunications
- Tertiary

STANDARD FUNCTIONS

- AC mcb with cont. aux.
- Floating charge
- Boost charge
- Manual charge
- Temperature compensation
- Test battery function
- **BEA** function (Battery Efficiency Analysis)
- DC earth pole sensor
- Relay alarm card

COMMUNICATION (Modbus slave TCP/IP)

Individual word for electrical parameters:

- Output voltage to loads
- Output current to loads
- Current battery charge
- Battery temperature

DoubleWord alarms:

- Showing all the signals present on the HMI

HMI PANEL

- Output voltage
- Output current
- Current battery charge
- Battery temperature

TITANIUM PLUS 1R-SCR

GENERAL	BATTERY	Suited for sealed (VRLA) or vented Lead Acid or NiCd battery			
	CHARGING CHARACTERISTICS	IU (according to DIN 41773) floating, boost and manual charging			
OUTPUT	NOMINAL VOLTAGE (V)	24	48	110	220
	CURRENT RANGE	60 ÷ 500 A			60 ÷ 250 A
	MAXIMUM POWER (W)	12000	24000	55000	55000
	RIPPLE NOISE (RMS)	1%			
	V _{out} SETTING RANGE	+/- 5%			
	VOLTAGE STABILITY	+/- 1%			
	V _{in} VARIATION SETTING	+/- 1%			
	LOAD VARIATION SETTING	+/- 1%			
	START-UP TIME	10 sec.			
INPUT	VOLTAGE RANGE	three-phase 400Vac ±10%			
	INPUT FREQUENCY	50 ÷ 60 +/-5%			
	EFFICIENCY (Typ.)	≥ 90 %			
	I70 INSULATION	4kV by transformer			
PROTECTIONS	INPUT	Automatic circuit breaker			
	BATTERY	Fuses			
	OUTPUT	Switch			
	OVERLOAD	<120% for 20 minuti, >150% for 5 secondi			
	CURRENT CURVE	Constant			
	OVERVOLTAGE	+ 10% V _n			
	UNDERVOLTAGE	- 50% V _n			
	OVERTEMPERATURE	Shut down. Automatic restart after temperature reset			
ALARMS	ALARM CARD WITH N.3 RELAYS SPDT 5A/250VAC	AC Mains presence, General Failure, Low Battery voltage			
	N. 4 USER PROGRAMMABLE RELAYS VIA HMI PANEL				
AMBIENT	OPERATING TEMPERATURE	-10+40°C			
	OPERATING HUMIDITY	< 95% without condensation			
	STORAGE TEMPERATURE	-20+70°C			
	NOISE LEVEL	according EN50091 < 60 dBA (typical value with forced ventilation in operation)			
STANDARDS	MARKING	CE			
	PROTECTION DEGREE	IEC 60529			
	EMC	EN 61000-6-2 EN 61000-6-4			
	STATIC CONVERTERS	EN 60146			
	DC-UPS (performance, routine test, requirements)	IEC 62040-5-3			
PROTECTION DEGREE (closed door)		IP31 standard, others on demand			
COLOR		RAL 7035 cabinet - RAL7012 roof and base			

* Relay normally operating in positive safety

DC POLARITY GROUNDED SENSOR

There is a fixed-threshold sensor (about 15mA, referring to the system's output terminals) that detects possible loss of insulation of the output poles and batteries present in the system. This sensor is **NOT similar** to an **INSULATION CONTROL** instrument but is provided to give an initial indication of any abnormality. The circuit detects the loss of insulation of the **POSITIVE** pole or the **NEGATIVE** pole differentiated. From HMI you can activate and deactivate the function.

AC/DC - THYRISTOR

It consists of a rectifier bridge in a fully controlled configuration.

FLOATING CHARGE

This recharge has two different phases:

- Phase 1: the current is constant and the voltage increases
- Phase 2: the current decreases and the voltage is constant.

When the recharging current falls below a certain value, the batteries are considered charged and the cycle is over. In this situation the output goes to the floating value which is the minimum value necessary for correct recharging maintenance battery.

WIRING

- Power cables AC and DC sections = FS17 CPR Cca- s3,d1,a3
- Signaling and control cables = FRO-HP CPR Cca-s3,d1,a3
- FLAT CABLE = Flame Classification FT1,FT2
- Data transmission cables = Cavo RJ45 - CAT5 FTP

ALARMS RELAY CARD

There is a board consisting of 7 alarm relays with SPDT type contact shown on removable and polarized printed circuit terminals. The electrical contacts have a range of 5Amp to 250Vac. There are three fixed alarms respectively:

- **AC MAINS PRESENCE** - wired in positive logic
- **GENERAL FAILURE** - wired in positive logic
- **LOW BATTERY VOLTAGE**

While it is possible to configure the remaining 4 from the HMI. From HMI you can configure 4 alarms depending on the menu on HMI.

INPUT TRANSFORMER

The power transformer is made with a core of first choice laminations (optional the solution with oriented crystals) and an electrostatic screen between primary and secondary. It produces the reduction of the input voltage to the most appropriate value for the operation of the conversion system and insulation from the network (4kV). The transformer is made with class F supports and insulators (155 ° C) while the windings are in electrolytic copper class H double insulation (220 ° C). There is an electrostatic shield connected to earth between primary and secondary. The transformers comply with the Standard CEI EN 61558-2-4-file 4971 classification CEI 96-7.

BATTERY EFFICIENCY ANALYSIS "B.E.A."

Advanced feature that determines the state of efficiency of the battery through the mathematical comparison between the real trend of the voltage during the discharge of the battery and the theoretical curve based on **Peukert's law**.



Via Gaetano Donizetti, 109/111 - 24030 Brembate Di Sopra (BG) - ITALIA
Geller Business Centre - D2 Building

Phone **+39 035 4379962** Fax **+39 035 592935**
info@zutronic.it - **www.zutronic.it**

